



# Instruction Manual

**Sweepmaster B1500 RH (6464.40)**

## Introduction

### **Preface**

Dear Customer,

We are certain that the excellent qualities of the vehicle will justify the faith you have shown in us through your purchase.

Your safety, and that of others, basically lies in your ability to control and operate the vehicle. Before using the equipment for the first time, read this original manual thoroughly, act according to the information contained and keep it in a safe place for future reference or subsequent owners. Please read the Chapter "Safety Information" prior to starting the vehicle to ensure it is operated and used safely.

The operating manual contains all the most important information regarding operation, maintenance and service. Throughout this operating manual, sections which concern safety are indicated by corresponding warning symbols. Should you have any questions in respect of the vehicle or operating manual, your authorized Hako dealer is available to provide help at any time.

Please be expressly advised that you cannot base any legal claims on the information contained in this manual. Ensure only original spare parts are used should any repairs be necessary. Only such original spare parts warrant that the equipment is reliably ready to use at all times. Subject to modification as required by technical advancement.

Valid as of: April 2014

**Hako GmbH**  
**D-23843 Bad Oldesloe**  
**Hamburger Str. 209-239**  
**Phone ++49 (0) 4531 8060**

### **Proper use**

The Sweepmaster is a sweeping intended for commercial use and has been exclusively designed for sweeping up dry and wet refuse from areas such as production plants, warehouses, car parks and pedestrian precincts. Any use beyond this is regarded as improper use. The manufacturer is not considered liable for any damage resulting from improper use; the user is solely responsible for all the risks. The sweeping

vehicle must not be used to clear up toxic, inflammable or other substances which represent a potential health hazard. Intended use also includes maintaining and observing the operating, maintenance and repair conditions prescribed by the manufacturer.

The Sweepmaster may only be operated, serviced and repaired by personnel who are familiar with the work involved and are aware of the risks.

Based on the conception, design and construction of the model introduced onto the market by us, the machine complies with the applicable basic safety and health requirements stipulated in the EC Directive (refer to Declaration of Conformity). This declaration is no longer considered valid in the event of modifications to the machine not authorized by us. The manufacturer is not deemed liable for any damage resulting from unauthorized modifications to the machine.

## Introduction

### Notes on warranty

The terms defined in the purchase agreement apply. Claims for compensation related to damage are excluded from the terms of warranty when the damage is the result of failure to observe regulations concerning service and maintenance. Maintenance work must be performed by authorized Hako service centers and confirmed in the "Maintenance Report" which serves as a warranty logbook.

The following are excluded from the terms of warranty: wear and tear through overuse, defective fuses, improper handling and use or unauthorized modifications. Claims under the terms of warranty are also annulled when damage occurs to the vehicle resulting from the use of parts or accessories not explicitly approved by us or from failure to observe maintenance regulations.

### Acceptance of the machine

Inspect the vehicle immediately on delivery for signs of transport damage. Replacement will be made when confirmation is provided immediately by the freight carrier with regard to the damage and the damage report is sent to

our authorized sales partner together with the consignment note.

### Disposing of the machine

Render the machine inoperable. It must not represent a source of risks to children. Dispose of the machine in accordance with the applicable local regulations. For further information on disposal and recycling, contact the authorized Hako dealer where you purchased the machine.



Used batteries with the recycling symbol contain reusable commodities. The heavy metals contained simultaneously represent a serious risk to health and to the environment. Never open batteries or damage them. Never touch, inhale or swallow any material inside batteries. Health hazard! Never allow batteries to pollute the environment. Risk of contaminating the ground and water! In accordance with the symbol with the crossed out bin, these batteries must not be disposed of in domestic waste. The return and recycling of old batteries must be agreed on with your authorized

Hako dealer in accordance with the Battery Law § 6 and § 8 (BattG).

### Regulations for approval

The Sweepmaster is an automotive machine within the terms defined in the Road Traffic Licensing Regulations (FZV §2, previously StVZO §18).

On request, the manufacturing plant can enclose a report with which to acquire the vehicle type approval. This report is used by the local vehicle registration office to produce a valid vehicle registration license (Vehicle Registration Certificate, Part 1).

An official license number is not necessary. A general inspection in accordance with § 29 StVZO (road traffic licensing regulation) is not required either because the vehicle is designed for a top speed under 20 kph. In accordance with the StVZO, the vehicle must carry a first-aid kit, warning triangle and the vehicle registration license when used on public roads, paths and pedestrian precincts.

If any attachments or conversions are made on the Sweepmaster, which affect the equipment described in the vehicle registration license and are not mentioned in the vehicle registration li-

## Introduction

cense, the license becomes invalid. To acquire a new vehicle registration license, the vehicle must be presented to an officially accepted expert to produce a new report. The report becomes the official vehicle registration license when the vehicle registration office applies the applicable stamp.

### **Driving license**

In accordance with the provisions on driving licenses, a person who intends to drive a motor vehicle constructed with a top speed in excess of 6 kph on public roads, paths and pedestrian precincts, must be in possession of a valid driving license. Drivers of the Sweepmaster require a driving license for automotive agricultural machines up to 25 kph (Class L or higher).

## Table of Content



<b>Introduction</b> . . . . .	<b>2</b>	2.8 Towing the vehicle . . . . .	26	5.6.3 Change hydraulic oil filter . . .	56
Preface . . . . .	2	<b>3 Operation</b> . . . . .	<b>27</b>	5.7 Sweeping unit . . . . .	57
Proper use . . . . .	2	3.1 Method of operation . . . . .	27	5.7.1 Side brushes . . . . .	58
Notes on warranty . . . . .	3	3.2 Operating elements . . . . .	28	5.7.2 Adjusting the side brushes . . .	59
Acceptance of the machine . . .	3	3.2.1 Operating panel A . . . . .	28	5.7.3 Changing the side brushes . . .	59
Disposing of the machine . . . .	3	3.2.2 Operating panel B . . . . .	32	5.7.4 Rotary brush . . . . .	60
Regulations for approval . . . .	3	3.2.3 Operating elements on the vehicle . . . . .	34	5.7.5 Setting the sweeping pattern	61
Driving license . . . . .	4	<b>4 Technical Data</b> . . . . .	<b>40</b>	5.7.6 Aligning the rotary brush parallel . . . . .	61
<b>1 Safety Information</b> . . . . .	<b>6</b>	<b>5 Maintenance and Service</b> . . . . .	<b>43</b>	5.7.7 Changing the rotary brush . . .	61
1.1 Safety and warning symbols . .	6	5.1 Hako system maintenance . . .	43	5.7.8 Adjusting the sealing strips . .	62
1.2 General information . . . . .	7	5.2 Maintenance report . . . . .	44	5.7.9 Changing the sealing strips . .	62
1.3 Operating information . . . . .	7	5.3 Maintenance plan . . . . .	45	5.7.10 Filter system . . . . .	63
1.4 Maintenance information . . . .	9	5.4 Seat console . . . . .	51	5.7.11 Cleaning the dust filter . . . .	64
1.5 Particular risks . . . . .	11	5.4.1 Opening the seat console . . .	51	5.7.12 Changing the dust filter . . . .	64
1.6 Environmental protection . . . .	11	5.5 Battery system . . . . .	52	5.8 Wheels and brakes . . . . .	65
1.7 Labels on the vehicle . . . . .	12	5.5.1 Total discharge signal transdu- cer (TSG) . . . . .	53	5.8.1 Checking tire wear . . . . .	65
<b>2 Operation</b> . . . . .	<b>16</b>	5.5.2 Charging batteries . . . . .	53	5.8.2 Changing tires . . . . .	65
2.1 Initial instruction . . . . .	16	5.5.3 Disassembling the batteries . .	53	5.8.3 Brakes . . . . .	65
2.2 Prior to starting up . . . . .	17	5.5.4 Installing the batteries . . . . .	54	5.9 Electronics . . . . .	66
2.3 Starting the vehicle . . . . .	18	5.5.5 Disposing of batteries . . . . .	54	5.9.1 Fuses . . . . .	66
2.4 Stopping and switching off the vehicle . . . . .	20	5.6 Hydraulic system . . . . .	55	5.9.2 Relays . . . . .	67
2.5 Sweeping operation . . . . .	21	5.6.1 Filling hydraulic oil . . . . .	56	5.10 Special equipment and replace- ment demands . . . . .	68
2.5.1 Empty the dirt hopper . . . . .	22	5.6.2 Changing the hydraulic oil . . .	56	<b>EC Declaration of Conformity</b>	<b>69</b>
2.6 Function faults . . . . .	24				
2.6.1 Service code table . . . . .	24				
2.7 Transporting . . . . .	26				

## Safety Information

### 1 Safety Information

#### 1.1 Safety and warning symbols

All sections related to personal safety, safety of the vehicle and environmental protection are assigned the following symbols throughout the operating manual:

Symbol	Risks to ...	Definition
Safety information 	persons or property	Safety information on preventing hazardous situations caused by failure to follow instructions or prescribed working procedures accurately or at all.
Note 	the machine	Important information on handling the equipment in order to maintain its functionality.
Ecological hazard 	the environment	Ecological hazard through the use of substances which represent a potential hazard to health and the environment.

## Safety Information

### 1.2 General information

- In addition to the information provided in this operating manual, all the legally applicable health and safety provisions must be observed.
- Before starting up the vehicle for the first time, read the operating manual supplied with it thoroughly as well as any separate manuals provided with additional or attachment devices and observe all the information during work.
- The vehicle may only be operated, serviced and repaired by personnel trained by Hako technical experts.
- This vehicle is not intended to be used by persons (including children) with limited physical or mental capabilities or persons without sufficient experience and ability.
- Particular attention should be paid to the information regarding safety. Technical expertise is the key to preventing errors when operating the equipment and ensuring trouble-free operation.
- The operating manual must always be kept at the operating location of the vehicle and, as a result, should be kept in a safe place on the vehicle.

- If the equipment is sold or rented out, these documents should be transferred to the new owner/operator. The transfer should be confirmed!
- The warning labels attached to the equipment provide important information concerning safe operation. Labels which are illegible or missing must be replaced.
- Original spare parts must be used to ensure safety.
- It is forbidden to move into the hazard area of the vehicle.
- A mobile phone may only be used when the vehicle has been stopped.
- It is forbidden to transport people on the vehicle!

### 1.3 Operating information

- Check the operational safety of the vehicle each time before starting it up! Clear any faults immediately!
- Before starting work, the operator must be fully familiar with all adjustment, operating and control elements as well as their respective function! It is too late to do this when the vehicle is actually in operation!
- Always wear heavy duty, non-slip footwear when working with the vehicle.
- The vehicle may only be driven on and the equipment used on those surfaces which have been approved by the contractor or person appointed by him.
- When using the vehicle, it is essential to pay attention to third parties, especially children.
- The vehicle is not suitable for clearing up hazardous, inflammable or explosive fluids, dust or substances.
- This vehicle must not be used as dust cleaner equipped with a dust filter insert (dust collector) to clear up dust which could represent a hazard to health.
- It is forbidden to use the vehicle in potentially explosive atmospheres.
- Remove the key from the key switch to prevent unauthorized use of the vehicle.
- The vehicle and its equipment must be checked in terms of perfect working condition and operational safety before being put to use. The vehicle must not be used if it is not in a proper working condition.
- Before putting the vehicle into operation, adjust the driver's seat so that

## Safety Information

you have a perfect view of the front and rear path of travel and working area!

- For safety reasons, the driver's seat is equipped with a seat contact switch. The vehicle can only be started when the operator is sitting on the driver's seat. The function of the seat contact switch must not be bypassed.
- The seat contact switch is monitored electronically. Any attempt at manipulation can lead to the vehicle being automatically locked against use.
- Always switch off all the drives before switching the vehicle on.
- The vehicle must only be started, put into motion and stopped from the seat.
- Ensure there is sufficient ventilation when sweeping in closed spaces (dust).
- The driving speed must always be adapted to the ambient conditions and load status.  
Three-wheel vehicles are less stable than four-wheel vehicles, therefore: avoid sudden steering movements when driving at higher speeds, taking corners at too high a speed could

cause the vehicle to tip.

Only use the vehicles on level surfaces, never on gradients.

Drive up and down inclines in straight lines.

When driving up, down or across slopes, avoid turning corners suddenly or in jerks. There is a risk of tipping when in an inclined position!

- Do not drive the vehicle on slopes with a gradient steeper than the limit gradient indicated on the vehicle.
- The approved gross total weight and permissible axle loads must never be exceeded. Check the fill level of the dirt hopper at frequent intervals.
- Before raising or lowering the dirt hopper, ensure that there are no persons, animals or items in the working area.
- Risk of crushing and shearing. Before raising or lowering the dirt hopper, ensure that there is a sufficient safety clearance.
- The dirt hopper may only be raised in the direct vicinity of the container. Only empty the dirt hopper on level, solid ground.
- Never sweep when the dirt hopper is in a raised position.

- Pay attention to any persons in the vicinity when emptying the dirt hopper.
- The filter may only be shaken when the dirt hopper has been closed.
- Never exceed the max. load capacity of the container!
- The vehicle may only be driven at creeping speed when the dirt hopper has been raised. Avoid any sudden steering movements or decelerations.
- When driving down a slope, use the brake to decelerate the vehicle.
- Before starting to drive, the seat console must be locked by means of the rollover bar (only with cab safety roof option).
- Do not use the vehicle in areas where the driver is at risk of being hit by falling objects (e.g. warehouses) without a protective roof structure (refer to the cab safety roof option)). Contact the trade association responsible for you as to whether obligations exist in this respect.



## Safety Information

### 1.4 Maintenance information

- Operating personnel must complete the necessary daily and weekly maintenance work. All other maintenance work must be completed at your nearest Hako service center.
- The maintenance work and maintenance intervals prescribed in the operating manual must be adhered to.
- Pay attention to any rotating parts before starting cleaning and maintenance work. They represent a risk of crushing!
- Suitable tools must be used for cleaning and maintenance work.
- The vehicle must be inspected by a recognized technical expert in respect of operational safety, within the terms of the applicable accident prevention laws, at reasonable intervals (we recommend at least once a year) and following modification or repairs .
- Spare parts must comply with the minimum technical requirements stipulated by the manufacturer! This is ensured by the use of original spare parts.
- Only use the rotary brushes and side brushes recommended by the manufacturer (refer to Technical Data). The use of other rotary brushes and side brushes could impair safety.
- The vehicle must be switched off prior to cleaning or servicing it or to replacing parts. The key must be removed from the key switch.
- The dirt hopper must be cleaned regularly to prevent the accumulation of bacteria.
- The vehicle is splashproof (IPX3). It is not permitted to clean the vehicle with a pressure washer or steam blaster.
- When transporting the vehicle, the vehicle must be switched off.
- If the Sweepmaster is jacked up with a jack, it must be properly supported.
- No persons may be on the Sweepmaster when it is jacked or raised.
- When changing wheels, the vehicle must be additionally secured from rolling away by placing wheel chocks against the wheels. Always change wheels on level, solid ground, where possible.
- Do not remove or replace tires or repair one on a rim. Always go to a proper workshop for work on tires and rims because they have specially trained personnel and special safety tools.
- Do not carry out any welding, drilling, sawing or grinding work on frame parts. Damaged parts may only be replaced by specialist workshops approved by Hako.
- Only use original fuses. Using fuses which are too powerful could damage the electrical installation and lead to fires.
- Always disconnect the negative pole of the battery when working on the electrical installation.
- Never leave the batteries in a discharged state but recharge them as soon as possible.
- Only refill distilled water. When the cells are in good condition, never refill the battery acid.
- To prevent current leaks, always keep the battery clean and dry, protect it from soiling by metallic dust, for example.
- Battery acid is very corrosive (keep out of reach of children). Wear protective goggles when controlling the acid level. In the event of acid splashing in the eyes, rinse them with water for approx. 15 min-

## Safety Information

utes and seek medical attention immediately.

Always wear appropriate protective clothing when handling the battery (e.g. protective gloves, finger stalls). Never use an open flame (risk of explosion).

- When installing or removing the battery or changing it, there is a risk of crushing and shearing.
  - Any fluids escaping under high pressure (e.g. hydraulic oil) can penetrate the skin and cause severe injuries. Seek medical attention immediately in order to prevent the risk of infection. Take care when draining hot oil - risk of burns.
  - Subject the brake system to a thorough inspection regularly! Adjustments and repairs to the brake system may only be completed by specialist workshops approved by Hako or recognized brake service workshops.
  - Subject the hydraulic system to a thorough inspection regularly! Adjustment and repair work on the hydraulic system may only be performed in specialist Hako workshops.
- Check hydraulic lines and hoses regularly for signs of damage and leaks. Replace damaged lines and hoses immediately.

## Safety Information

### 1.5 Particular risks

#### Safety equipment

- Never operate the Sweepmaster without effective safety equipment (this includes the side door lock)!

#### Electronics

- Only use original fuses with the prescribed amperage.
- In the case of defects in the electrical installation, switch the vehicle off immediately and clear the fault.
- Work on the electrical equipment may only be carried out by electricians who have received the necessary training and in accordance with the electrical engineering regulations.
- The vehicle's electrical equipment must be inspected/checked at regular intervals. Defects, such as loose connections and cable damage, must be rectified immediately.
- Observe the information in the operating manual provided by the battery manufacturer.
- Never lay any metallic objects or tools on batteries - risk of short circuit!
- Ensure sufficient ventilation in the charging area when charging the

batteries – risk of explosion!

Open the seat cover during the charging process.

### 1.6 Environmental protection

- A certain factual expertise is required in order to use substances which could represent a risk to health and the environment.
- Always observe legal regulations and local directives when disposing of cleaning agents, refer to the Water Resources Act.
- Used batteries with the recycling symbol contain reusable commodities. In accordance with symbol with the crossed out garbage bin, these batteries must not be disposed of in domestic waste. The return and recycling of old batteries must be agreed on with your authorized Hako dealer in accordance with the Battery Law § 6 and § 8 (BattG).

# Safety Information

## 1.7 Labels on the vehicle

The following safety and warning labels are attached to the vehicle where easily legible. Missing or illegible labels must be replaced immediately.

Company logo (Fig. 1/1), front and rear



Rating plate (Fig. 1/2)



Vehicle identification number (Fig. 1/3)

**6464xxxxxxxx**

Machine model (Fig. 1/4)

**Sweepmaster B1500 RH**

Parking brake (Fig. 1/5)



Read and observe the operating manual (Fig. 1/6)



High-pressure washer/Steam cleaner (Fig. 1/7)



Sound power / Gradient (Fig. 1/8)

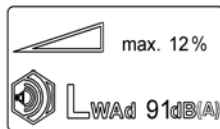

Pressing force (Fig. 1/9)



Front skirt (Fig. 1/10)



Fuses (Fig. 1/11)

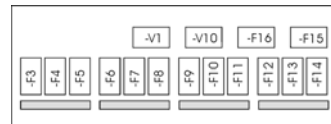

Risk of crushing by dirt hopper (Fig. 1/12)



# Safety Information

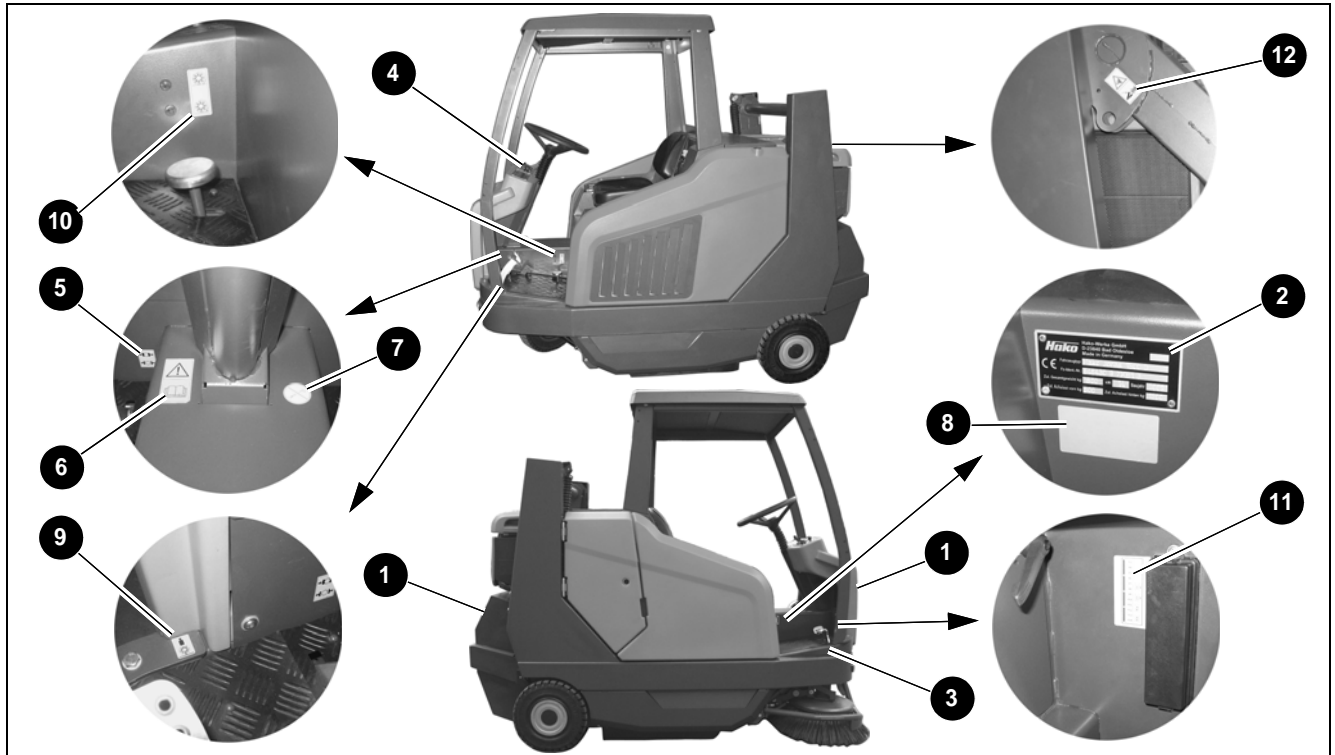

Fig.1

## Safety Information

Brush wear compensation (Fig. 2/1)



Keep clear of dirt hopper (Fig. 2/2)



Hydraulic oil (Fig. 2/3)



Risk of crushing by dirt hopper (Fig. 2/4)



## Safety Information

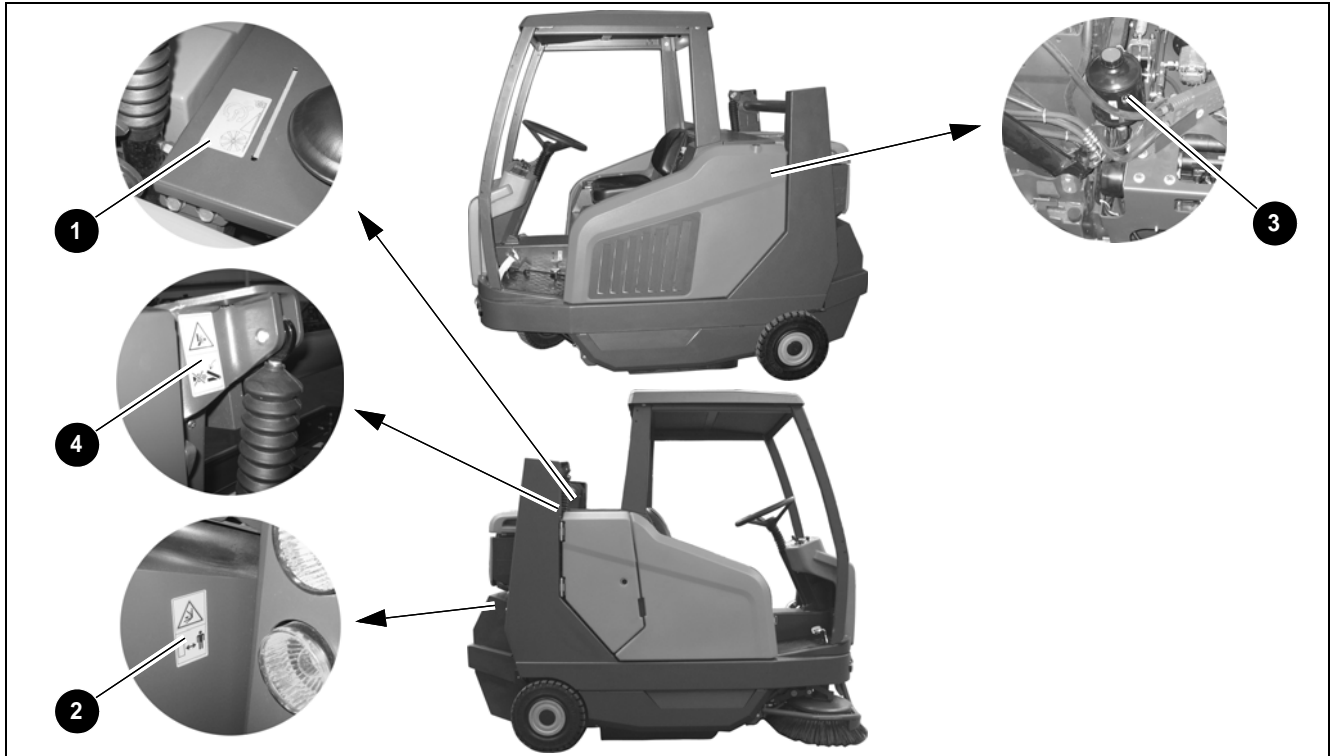

Fig.2

## 2 Operation

### 2.1 Initial instruction

Instructions to operators are required before putting the machine into service. Only technicians from your local authorized Hako dealer are allowed to provide initial instruction on the machine. The manufacturing plant will notify the dealer immediately after delivering the vehicle and the dealer will contact you to arrange a date.



## Operation

### 2.2 Prior to starting up



Read the operating instructions concerning the vehicle provided in Chapter 1, observed them and familiarize yourself with the operating procedures.

1. Check the parking space for signs of leaks. Hoses, lines and tanks must show no signs of leaks or damage.
2. Check the battery charge status (Fig. 3/1); charge the battery, if necessary.
3. Check the hydraulic oil level in the hydraulic tank (Fig. 3/2), refill if necessary.
4. Check the adjustment of the driver's seat (Fig. 3/3).
5. Check the steering wheel adjustment, readjust with the lever (Fig. 3/4), if necessary.
6. Lock the seat console (only with the cab safety roof option), refer to Section 5.4.1.

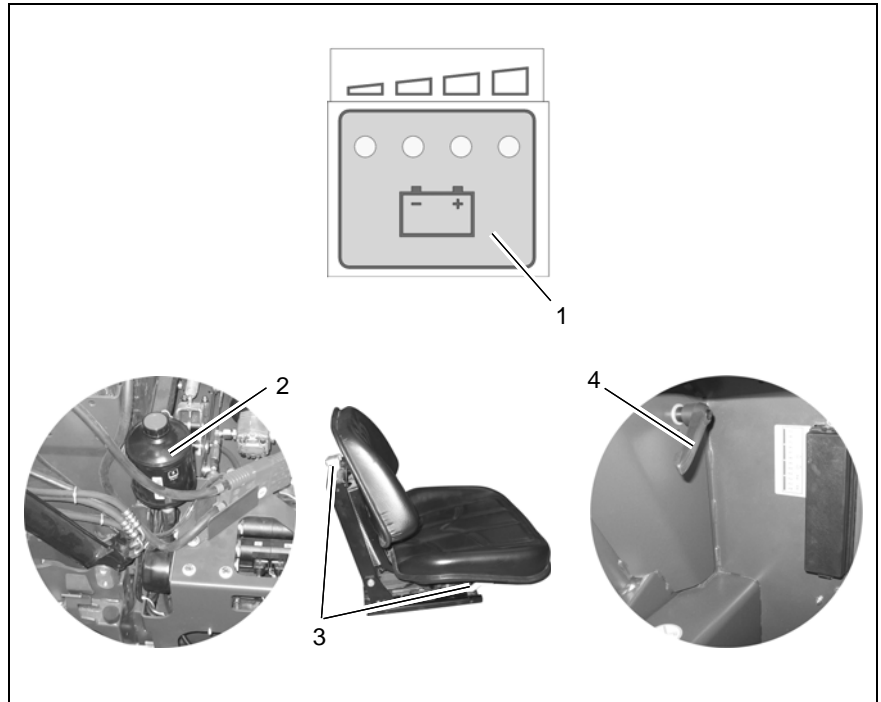

**Fig.3**

## Operation

### 2.3 Starting the vehicle



Pay attention to the following information before starting the vehicle:

- For safety reasons, the driver's seat is equipped with a seat contact switch. The vehicle can only be started when the operator is sitting on the driver's seat. The function of the seat contact switch must not be bypassed.
- The seat contact switch is monitored electronically. Any attempt at manipulation can lead to the vehicle being automatically locked against use.
- The vehicle may only be used in ambient temperatures of 0°C to 40°C. Full loads should only be applied to the units on reaching operating temperature.

## Operation

### Procedure to start the vehicle:

1. Make sure that all control levers are off or set to zero.
2. The vehicle's parking brake must be applied (Fig. 4/2).
3. Connect the battery plug (Fig. 4/3) to the device connector.
4. Turn the key switch (Fig. 4/4).
  - The operating hour counter (Fig. 4/A) displays the software version, possibly the last diagnostic code and the operating hours in succession.

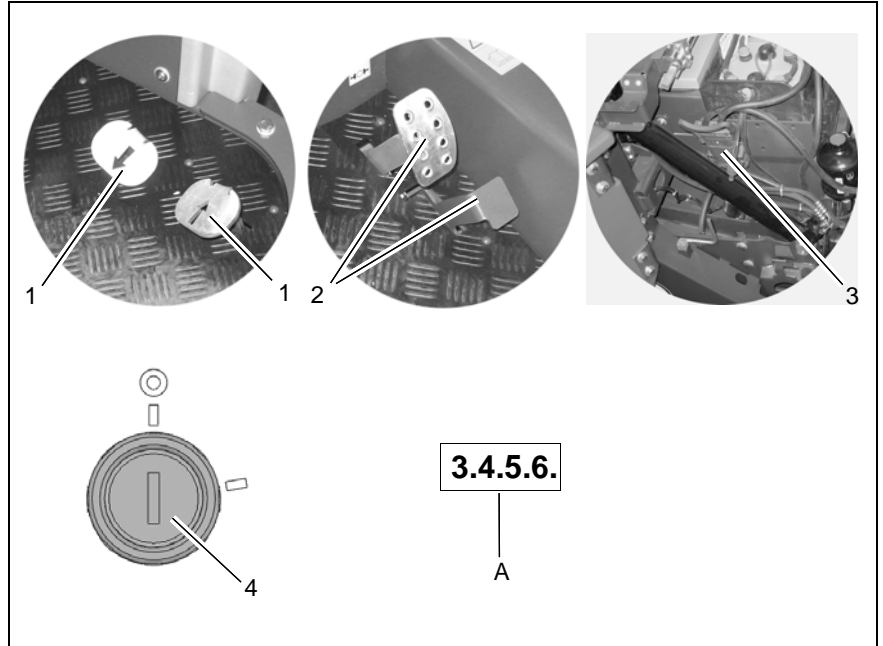

**Fig.4**

## Operation

### 2.4 Stopping and switching off the vehicle

1. Move the accelerator (Fig. 5/1) slowly to its zero setting. The vehicle slows down to a stop.
2. Apply the parking brake (Fig. 5/2) to its end position and lock in place.
3. Switch off the sweeping functions with the button (Fig. 5/A).
4. Switch off the vehicle with the key switch (Fig. 5/3).



Remove the key when getting off the vehicle to prevent unauthorized use.

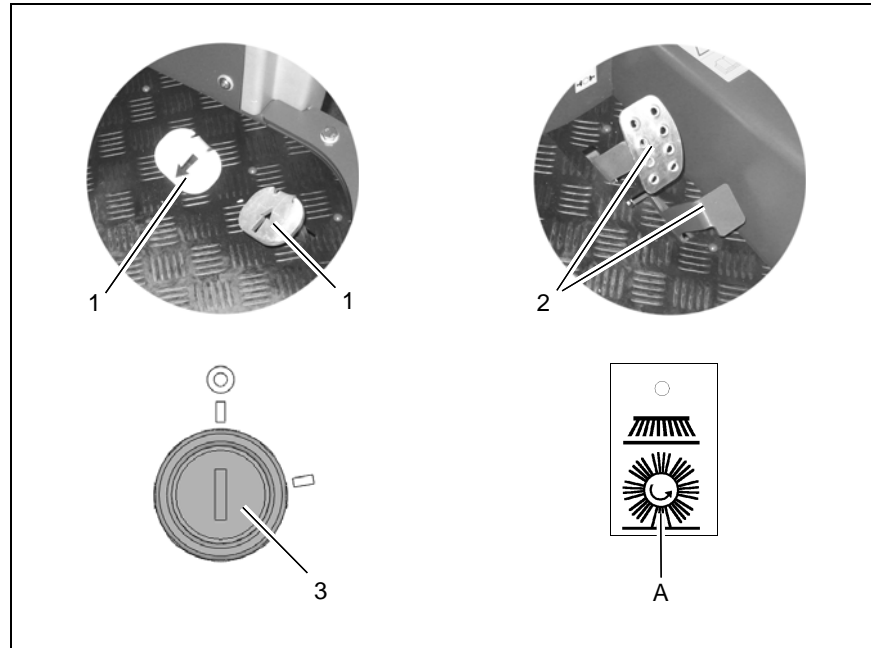

Fig.5

## Operation

### 2.5 Sweeping operation

1. Check the vehicle, refer to Section 2.2.
2. Start the vehicle, refer to Section 2.3.
3. Switch on the sweeping function with the button (Fig. 6/A). The rotary brush, side brush and suction turbine are activated.
4. In the case of damp waste, switch the suction turbine off with the button (Fig. 6/B).
5. Release the parking brake (Fig. 6/2) to its end position.
6. Slowly press the accelerator (Fig. 6/3) until the required driving speed is reached.
7. It is recommended to clean the filter regularly. To do this, actuate the button (Fig. 6/C).
8. Check the contents of the dirt hopper regularly. Empty the dirt hopper as necessary.

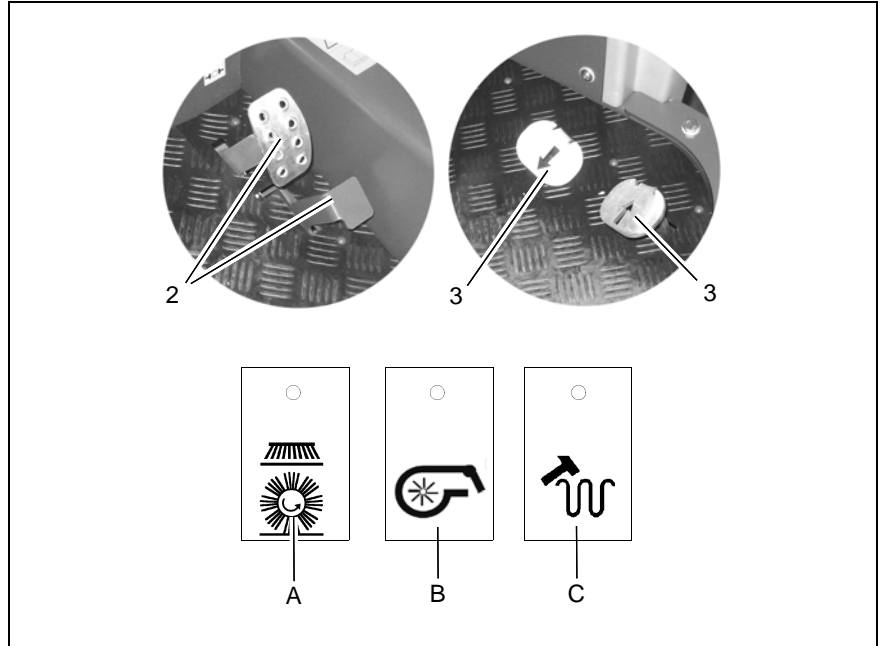

Fig.6

### 2.5.1 Empty the dirt hopper



Observe the following safety information before emptying:

- Driving the vehicle with the dirt hopper raised reduces the vehicle's stability. Therefore, only raise the dirt hopper immediately prior to emptying it.
- Only raise the dirt hopper when the vehicle is on a horizontal surface.
- Before raising the dirt hopper, the operator must have ensured that there are no persons or objects behind or beside the vehicle.
- The vehicle may only be driven slowly when the dirt hopper is raised.
- It is forbidden for anyone to move into the danger area. Risk of crushing and shearing!
- Before raising or lowering the dirt hopper, ensure that there is a sufficient safety clearance.
- The dirt hopper can only be tipped when the hopper has been raised beyond a minimum height.

## Operation

### Procedure to empty the dirt hopper:

The dirt hopper must be emptied at regular intervals. Ensure the maximum fill weight is never exceeded.

1. Switch off the sweeping functions with the button (Fig. 7/F). The filter agitation system is activated.
2. Agitate the filter too, if necessary. To do this, actuate the button (Fig. 7/E).
3. Raise the dirt hopper. To do this, press and hold the button (Fig. 7/A) until the hopper is lifted to the height required.
4. Drive backwards, slowly! Empty the dirt hopper. To do this, press and hold the button (Fig. 7/B) until the dirt hopper is pivoted vertical.
5. Pivot the dirt hopper back again by pressing the button (Fig. 7/C).

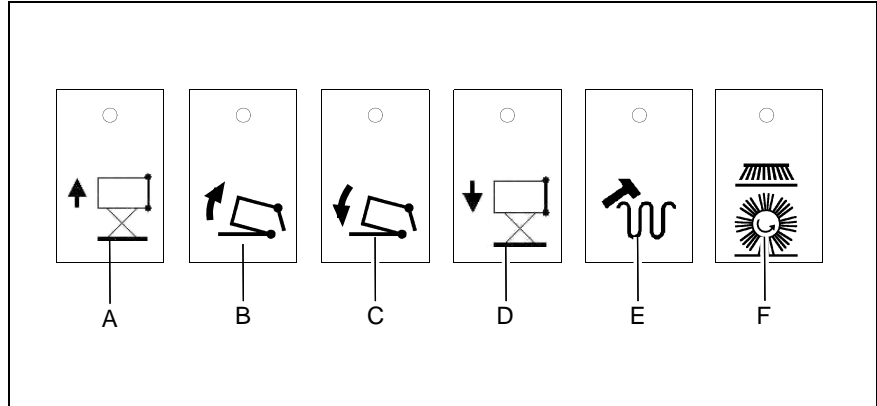

**Fig.7**

6. Drive the Sweepmaster away from the garbage container and lower the dirt hopper to its end position using the button (Fig. 7/D). The end position is detected and the dirt hopper is pivoted back automatically, if necessary.

## Operation

### 2.6 Function faults



The following applies when locating and clearing faults: Switch the vehicle off, remove the key from the key switch!

#### 2.6.1 Service code table

In the case of system errors, a four-digit error code appears in the left-hand operating panel in addition to the service indicator (wrench symbol). The dots in the service code flash.

Clear the fault or note down the service code and inform your authorized Hako dealer. When the cause has been cleared, the error must be acknowledged by switching the key switch OFF/ON.

Error code	Cause	Solution
2.2.5.1.	Rotary brush motor too hot: Sweeping pattern is too large, foreign bodies in the rotary brush	Adjust the sweeping pattern, remove foreign bodies
2.2.6.1.	Rotary brush stops, engine is switched off, sweeping is switched off: Foreign bodies, tape or such is blocking the rotary brush, motor is briefly overloaded	Check the rotary brush for foreign bodies and remove any, check sweeping pattern
2.3.5.1.	Side brush motor, left/right, is too hot: Brush application area too large, foreign bodies (such as tape) tangled in the side brush	Adjust the brush application area, check side brush for foreign bodies
2.3.6.3. 2.3.6.5	Side brush, left/right (2.3.6.3./2.3.6.5.) stops, motor is switched off: Foreign bodies (such as tape) tangled in the side brush, engine is briefly overloaded (in case of strong side pressure, e.g. against curb, wall etc. an acoustic signal is issued and the side brush motor is switched off briefly; if this occurs three times, the side brush motor and holding attachment are switched off)	Check the side brush for foreign bodies and remove them, check ground contact pattern



## Operation

<b>Error code</b>	<b>Cause</b>	<b>Solution</b>
2.4.5.1.	Fan motor too hot: Foreign bodies in belt drive or extractor fan, defective filter - flow of air too large	Clear any foreign bodies, replace filter
3.1.6.2.	Agitating motor, side brush, rotary brush functions switched off, individually or all: A safety fuse on module 3E/Code A (A2) s defective	Replace the defective fuse
3.1.6.3.	Raise/Lower/Pivot dirt hopper function switched off, individually or all: A safety fuse on module 3E/Code B (A3) is defective	Replace the defective fuse
3.1.6.7.	All functions controlled via modules 3E/CA+B fail: A safety fuse on module 3E/CB(A3) is defective	Replace the defective fuse
3.1.6.8.	A safety fuse on module A8 is defective	Replace the defective fuse
3.1.6.9.	A safety fuse on module A7 is defective	Replace the defective fuse
3.3.5.1.	Hydraulic pump too hot	Allow the motor to cool down.
3.4.5.1.	Hydraulic motor too hot or overloaded: Vehicle switches to 1/2 speed	Allow the motor to cool down.

## Operation

### 2.7 Transporting

In order to transport the vehicle on a loading space, apply the parking brake and also secure the vehicle using straps at both front lashing points (Fig. 8/1) and the two rear lashing points (Fig. 8/2) which are located in the wheel case.

### 2.8 Towing the vehicle

Towing distance: Max. 500 m to move the machine from the hazard area.  
Towing speed: Max. 5 kph. The two front lashing points (Fig. 8/1) can be used as towing lugs.

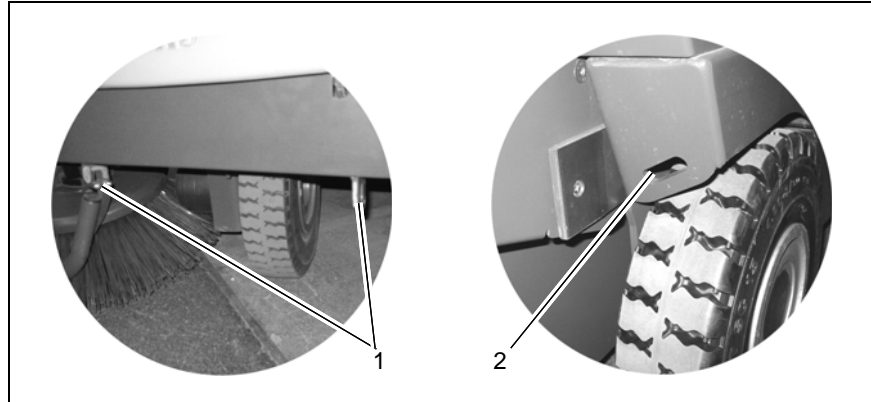

Fig.8

## 3 Operation

### 3.1 Method of operation

#### General information

The Sweepmaster is a sweeping vehicle exclusively designed for sweeping up dry and wet waste from floor surfaces as in production plants, warehouses, car parks and pedestrian precincts.

#### Sweeping

The side brush (Fig. 9/1) sweeps the dirt directly into the pick-up path (Fig. 9/2) of the rotary brush (Fig. 9/2). The rotary brush sweeps the dirt overhead (Fig. 9/3) into the sweeping container (Fig. 9/4). The particulate matter (Fig. 9/5) swirled up is vacuumed up by the suction turbine (Fig. 9/7) and forced against the filter (Fig. 9/6) which filters it. Dirt disposal with the sweeping container is realized via hydraulic lift-up (Fig. 9/8).



Fig.9

## Operation

### 3.2 Operating elements

#### 3.2.1 Operating panel A

- 1 Not used
- 2 Not used
- 3 Control lamp for parking brake
- 4 Control lamp for service indicator
- 5 Operating hour counter / Service code
- 6 Charge status indicator
- 7 Not used
- 8 Button to raise the dirt hopper
- 9 Button to pivot the dirt hopper for emptying
- 10 Button to pivot the dirt hopper back
- 11 Button to lower the dirt hopper
- 12 Button for the filter agitation system with control lamp
- 13 Button for the suction turbine
- 14 Button for the rotary brush
- 15 Button for the rotary brush and side brush

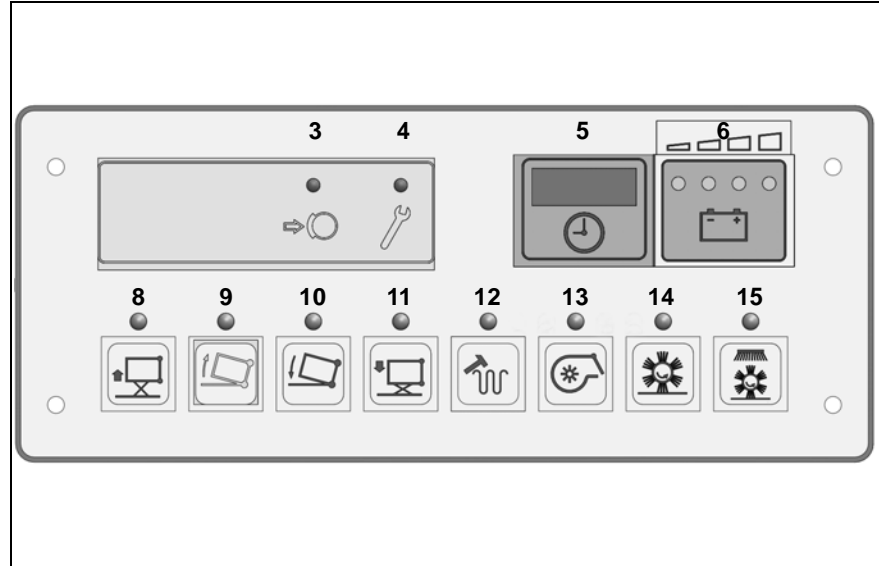
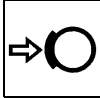

Fig.10



### Control lamp for parking brake (Fig. 10/3)

It lights up when the parking brake is actuated. The control lamp goes out when the parking brake is released. The buzzer sounds if the accelerator is pressed when the parking brake is actuated.



### Control lamp for service indicator (Fig. 10/4)

It lights up when an error has occurred in the system. In addition to the Service indicator, a four-digit service code appears in the operating hour counter display. The dots in the service code flash. Clear the fault or note down the service code and inform your authorized Hako dealer. After clearing the fault, acknowledge it by turning the key switch OFF/ON.

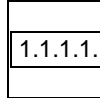

### Operating hour counter/Service code (Fig. 10/5)

The software version, last service code and current operating hour status appear in the operating hour counter display briefly after switching the ignition on. If the display flashes, it means the driver's seat is not occupied. A list of possible errors is provided in Section 2.6.1.

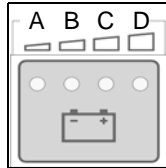

### Charge status indicator (Fig. 10/6)

After switching on the key switch, all the lamps light up if the battery is fully charged. As the battery is discharged during operation, the lamps (B), (C) and (D) go out according to the respective charge level. The critical discharge level is indicated when the red lamp (A)

flashes and, at the same time, an acoustic signal is issued. At this moment, drive the shortest possible route to the charging station. After the lamp has flashed for 3 minutes, the cleaning units are automatically switched off (side brush, main rotary brush, fan). The drive remains active. The vehicle can still be driven for a limited time when the red lamp flashes according to the battery status. When the red lamp lights up continuously, all the vehicle functions are deactivated and the driving speed is reduced by half. This serves to protect the battery from total discharge.

## Operation

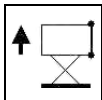

### Button to raise dirt hopper (Fig. 10/8)

It serves to raise the dirt hopper. To raise the dirt hopper, press the button until the it is at the required height. The control lamp in the button lights up. If the button to raise the dirt hopper is pressed during sweeping operation, the sweeping function is deactivated.

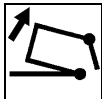

### Button to pivot the dirt hopper for emptying (Fig. 10/9)

It serves to pivot the dirt hopper to a vertical position for emptying. The control lamp in the button lights up. The dirt hopper can only be tipped when the hopper has been raised beyond a minimum height.

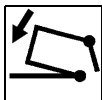

### Button to pivot the dirt hopper back (Fig. 10/10)

It serves to pivot the dirt hopper horizontal because it can only be lowered when in a horizontal position. The control lamp in the button lights up.

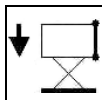

### Button to lower the dirt hopper container (Fig. 10/11)

It serves to lower the dirt hopper. To lower the hopper, press the button as long as necessary until the hopper is against the frame. The control lamp in the button lights up. The dirt hopper pivots in automatically if it is still not in a horizontal position for lowering.

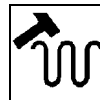

### Button for filter agitation system (Fig. 10/12) with control lamp

On actuating the switch, the agitating device is switched on and the filter system cleaned. The agitation process takes approx. 15 seconds. The control lamp in the button lights up. During the agitation process, the suction turbine is automatically deactivated.

If the control lamp in the button starts to flash (with a single acoustic warning), the filter is extremely soiled and must be shaken clean.

## Operation



### **Button for suction turbine (Fig. 10/13)**

It serves to switch the suction turbine on and off. When the suction turbine is switched on, the control lamp in the button lights up. If the control lamp flashes, the suction turbine is in the switching on or off phase.



Switch the suction turbine off in the case of wet waste.



### **Button for rotary brush (Fig. 10/14)**

It serves to switch the rotary brush on and off. When the rotary brush is switched on, the control lamp in the button lights up.



### **Button for sweeping functions (Fig. 10/15)**

It serves to switch the sweeping operations on and off. The rotary brush, side brush and suction turbine are switched on and off.

## Operation

### 3.2.2 Operating panel B

- 1 Key switch
- 2 Not used
- 3 Not used
- 4 Horn switch
- 5 Switch for parking light/driving lights (option)
- 6 Switch for hazard lights (option)
- 7 Switch for flashing beacon (option)
- 8 Switch for drive direction indicator with control lamp (option)

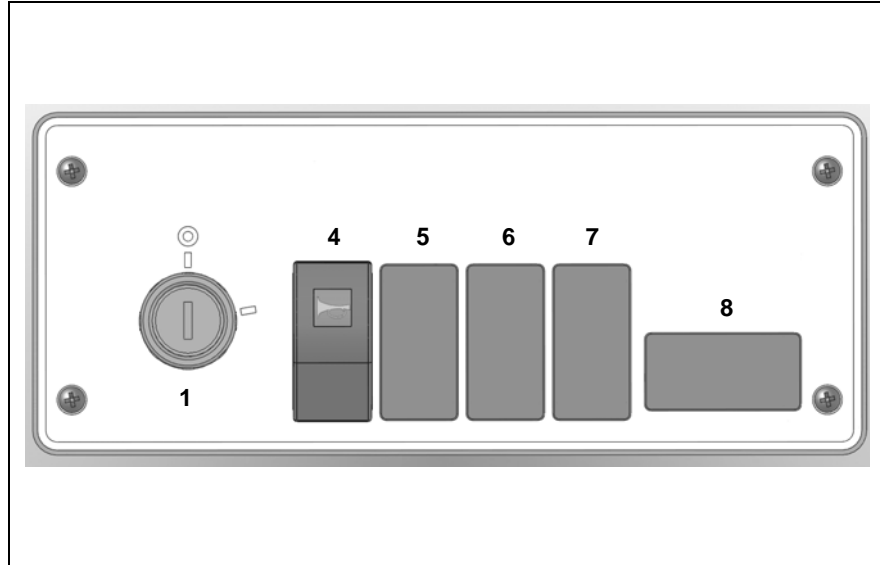
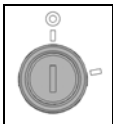

Fig.11



## Operation



### Key switch (Fig. 11/1)



Ensure all the operating controls are in their neutral position when the vehicle is switched on.

It serves to switch the electrical system on/off, to protect the vehicle from unauthorized use by removing the key and to acknowledge a diagnostic code.



For reasons of safety, the vehicle is equipped with a seat contact switch. The vehicle can only be started when the operator is sitting on the driver's seat. If the seat contact is interrupted, all the functions are switched off and the operating hour counter flashes.

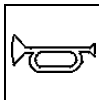

### Switch for horn (Fig. 11/4)

An acoustic signal is issued on actuating the switch.

### Switch for parking light/driving lights (option)(Fig. 11/5)

The switch serves to switch the parking light/driving lights or working lights on and off.

### Switch for hazard lights (option) (Fig. 11/6)

This function is only provided when the lighting system option is installed.

### Switch for flashing beacon (option) (Fig. 11/7)

The switch serves to switch the flashing beacon on/off. It functions even when the key switch is switched off.

### Switch for drive direction indicator with control lamp (option) (Fig. 11/8)

The switch serves to select the driving direction:

To change the driving direction, stop the vehicle by applying the service brake, select the new direction and accelerate again.

## Operation

### 3.2.3 Operating elements on the vehicle

#### Accelerators

They serve for driving forward and in reverse and simultaneously control the speed. If the pedal is released, it automatically returns to its zero position and the vehicle is decelerated to a stop. Accelerator (Fig. 12/1): Reverse drive Accelerator (Fig. 12/2): Forward drive

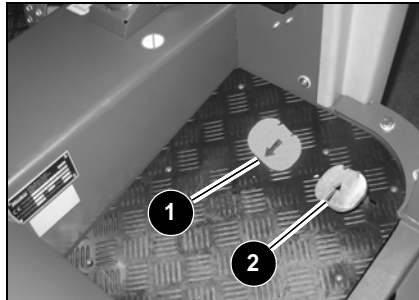

Fig.12

#### Service brake and parking brake

The service brake (Fig. 13/1) actuates the mechanical drum brakes which act on the two rear wheels. Before getting off the vehicle, apply the parking brake and lock it with the lever (Fig. 13/2). After actuating the brake pedal again, the lock is released.

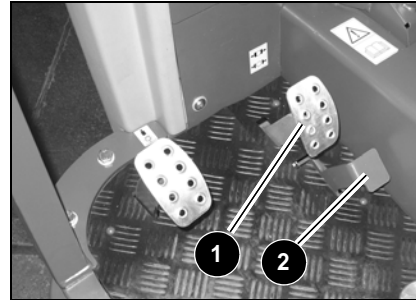

Fig.13

#### Pedal for rotary brush pressure

The pedal (Fig. 14/1) serves to increase the rotary brush pressure applied on the ground while sweeping. After releasing the pedal, the rotary brush moves back to its initial position.



Fig.14

## Operation

### Pedal for front skirt

The pedal (Fig. 15/1) can be used to raise the front skirt in the case of larger debris.

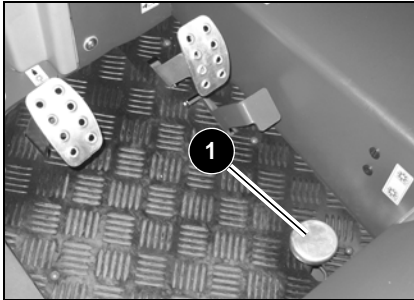

Fig.15

### Crank for setting the sweeping pattern

The crank (Fig. 16/1) is used to set the sweeping pattern of the rotary brush. Refer to Chapter "Maintenance and Service" for information on setting the sweeping pattern.

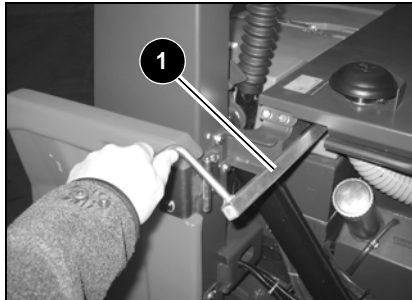

Fig.16

### Locking the seat console

For reasons of safety, the seat console is equipped with a lock (Fig. 17/1) (only with the cab safety roof option).



Before starting to drive, ensure that the seat console is secured by the lock!

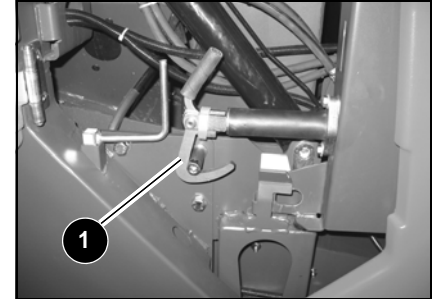

Fig.17

## Operation

### Checking the dirt hopper

The dirt hopper is provided with an opening in order to throw in waste collected manually. The fill volume of the dirt hopper can be monitored through the opening (Fig. 18/1).

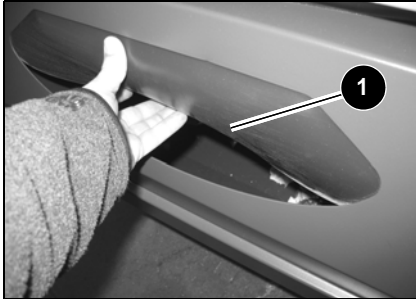

Fig.18

### Filter system lock

The filter system is above the dirt hopper. The cover of the filter system is secured by the lock (Fig. 19/1). The filter and agitation device is under the cover. Refer to Chapter "Maintenance and Service" for information on cleaning the filter.

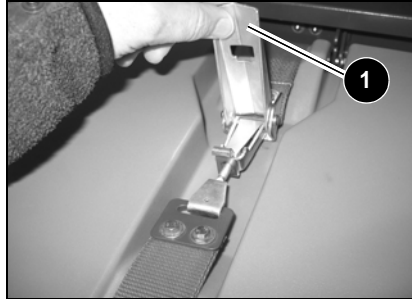

Fig.19

## Operation

### Driver's seat

The driver's seat (Fig. 20/1) must be adjusted so that the driver is seated comfortably and can reach all the operating elements with ease.

- The seat suspension can be adapted to the driver's weight (50 to 120 kg) using the handwheel (A).
- The driver's seat is released by means of the lever (B) and can be adjusted in a longitudinal direction.



For reasons of safety, the vehicle is equipped with a seat contact switch. The vehicle can only be started when the operator is sitting on the driver's seat. If the seat contact is interrupted, all the functions are switched off and the operating hour counter flashes.

Any attempt to manipulate the seat contact switch can lead to the vehicle being automatically locked against use.



Fig.20

## Operation

### Cab (optional)

#### Swinging the cab up

The cab can be swung up for maintenance work. Please follow the order described below, since otherwise the cab or machine may be damaged.

1. Switch the engine off and close the cab door.
2. Open the side flap and fit the pump lever onto the hand pump (Fig. 21/1).
3. Set the control lever (Fig. 21/2) on the pump to "raise" (arrow upwards) and pump the cab up with the pump lever until it moves no further.
4. Pull off the pump lever, place it in the holder and close the side flap again.

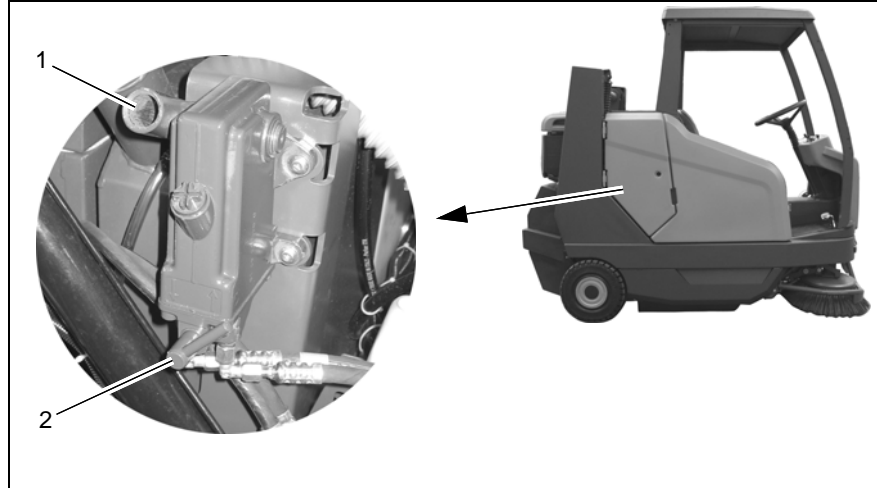

Fig.21

## Operation

### Lowering the cab

1. Switch the engine off and close the cab door.
2. Open the side flap and fit the pump lever onto the hand pump (Fig. 22/1).
3. Set the handle (Fig. 22/2) on the pump to "LOWER" (arrow downwards) and pump the cab down with the pump lever until it moves no further.
4. Pull off the pump lever, place it in the holder and close the side flap again.

### Switch for wiper

The wiper is switched on and off with the switch (Fig. 22/3). The wiper switches off in the end position.

### Opening the rear window

Unlock the rear window with the lever (Fig. 22/4) and set it in the required position.

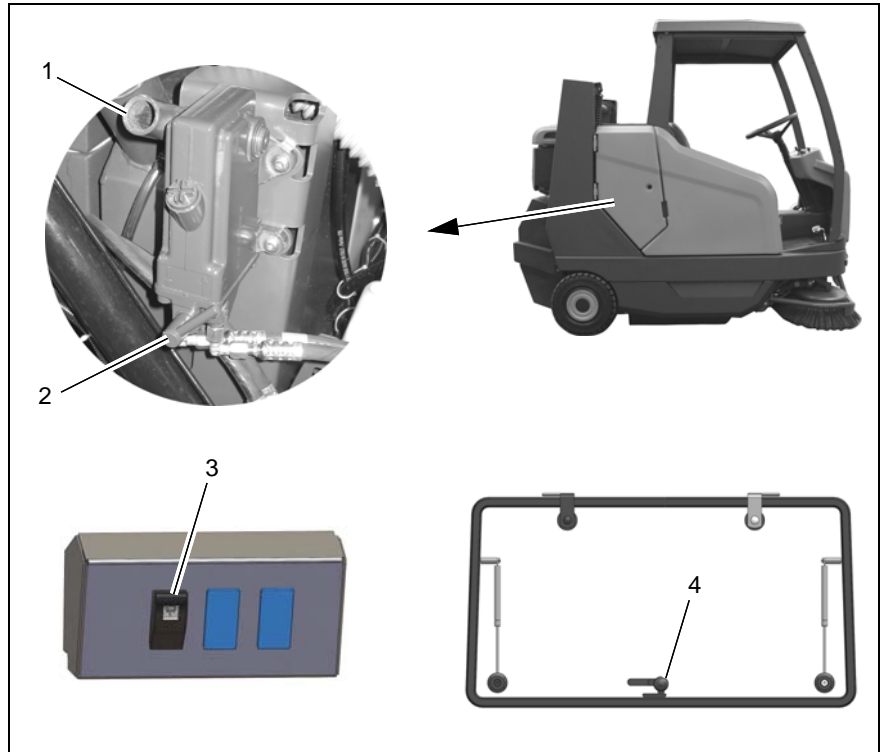

Fig.22

## Technical Data

### 4 Technical Data

<b>Dimensions and weight</b>		
Length	mm	2260
Width with/without left-hand side brush	mm	1320/1360
Height with/without protective roof	mm	1751/1985
Dead weight	kg	1560
Permissible total weight	kg	2350
<b>Driving and sweeping performance</b>		
Driving speed - forwards	kph	0-8
Driving speed - reverse	kph	0-4
Max. sweeping speed	kph	8
Theoretical sweeping performance with/without left-hand side brush	m <sup>2</sup> /h	10160/7360
Max. driving gradient	%	12
<b>Rotary brush</b>		
Length / Diameter	mm	920/500
Wear limit diameter	mm	400
Speed	rpm	540 +/-40
Sweeping pattern	mm	75 +/-10



## Technical Data

<b>Dirt hopper and filter system</b>		
Dirt hopper volume	Liter	240
Filter surface	m <sup>2</sup>	7,5
<b>Side brushes</b>		
Diameter	mm	600
Speed	rpm	Max. 95
<b>Wheels</b>		
Tires, front (wheel rims: diameter/width)	mm	310/120
Tires, rear	CSE	4.00-8
<b>Hydraulic system</b>		
Hydraulic oil, e.g. Mobiloil		DTE 25M or DTE 10 Excel46
Tank volume	Liter	1.5
<b>Electrical installation</b>		
Voltage	V	36
Max. battery capacity	Ah	325/450
Drive (P1)	W	2700
Brush drive (P1)	W	1900
Side brush drive (P1)	W	310
Fan drive (P1)	W	1000
Agitating motor (P1)	W	190
Protection class against penetration by moisture		IPX3

## Technical Data

<b>Noise emission values</b>		
The sound pressure level (LpA) (at the ear of the operator) measured according to DIN IEC 60335-2-72 under normal working conditions is:	dB (A)	79
Measurement inaccuracy (KpA):	dB (A)	2
The sound power level (LwAd) measured according to EN 60335-2-72 under normal under working conditions is:	dB (A)	91
The sound power level (LwAd) measured according to 2000/14/EC under normal working conditions is:	dB (A)	91
<b>Vibration values</b>		
The weighted, effective value of the acceleration, established in accordance with ISO 5349-1, to which the upper limbs (hand-arm) are exposed under normal working conditions is:	m/s <sup>2</sup>	< 2.5
The weighted, effective value of the acceleration, established in accordance with ISO 2631-1 to which the lower limbs (feet-seat surface) are exposed under normal working conditions is:	m/s <sup>2</sup>	< 0.5

### 5 Maintenance and Service

#### General information



It is essential to pay attention to the information in Chapter "Safety Information" before completing any service or maintenance work!

By adhering to the maintenance work recommended by us, you can be sure that the vehicle is always ready to be put into operation.

Maintenance and repair work necessary on a daily and weekly basis can be carried out by a driver trained to complete the work, all other Hako system maintenance may only be completed by personnel who are correspondingly qualified and trained. In case of doubt, please contact your nearest Hako service center or authorized Hako dealer. Failure to observe this annuls any rights to claims under the terms of guarantee in respect of resulting damage or consequential damage.

Always specify the serial number, indicated on the rating plate, when making any inquiries and orders for spare parts, refer to Section 1.7 - Rating plate.

#### 5.1 Hako system maintenance

Hako system maintenance:

- ensures the Hako working vehicle is always ready for operation (preventive maintenance),
- minimizes operating costs, maintenance and repair costs,
- ensures the vehicle has a long service life.

The Hako system maintenance describes the specific technical work necessary for the individual modules and defines the intervals for the maintenance tasks. Individual parts which must be changed during maintenance tasks are defined and stipulated in spare parts kits.

#### **Hako system maintenance, customer:**

Work to be carried out by the customer according to the service and maintenance instructions in the operating manual (daily and weekly). The driver/operator receives detailed instruction when the vehicle is delivered.

#### **Hako system maintenance, one-off** (After 50 operating hours)

Must be completed by a skilled technician in an authorized Hako service cen-

ter according to the vehicle-specific system maintenance with a spare parts kit.

#### **Hako system maintenance I:**

(Every 250 operating hours)

Must be completed by a skilled technician in an authorized Hako service center according to the vehicle-specific system maintenance with a spare parts kit.

#### **Hako system maintenance II:**

(Every 500 operating hours)

Must be completed by a skilled technician in an authorized Hako service center according to the vehicle-specific system maintenance with a spare parts kit.

#### **Hako system maintenance III/S:**

(Every 1000 operating hours, safety check)

Must be completed by a skilled technician in an authorized Hako service center according to the vehicle-specific system maintenance with a spare parts kit. All the legally prescribed safety-relevant tests must be completed in accordance with UVV-BGV-TÜV-VDE.

# Maintenance and Service

## 5.2 Maintenance report

<p style="text-align: center;"><b>Handover</b></p> <p>Upgrading Test drive Handover to customer Instruction completed on:  at _____ operating hours</p>	<p style="text-align: center;"><b>Hako System Maintenance I 50 operating hours, one-off Workshop Stamp</b></p> <p>completed on: at _____ operating hours</p>	<p style="text-align: center;"><b>Hako System Maintenance I 250 operating hours Workshop Stamp</b></p> <p>completed on: at _____ operating hours</p>	<p style="text-align: center;"><b>Hako System Maintenance II 500 operating hours Workshop Stamp</b></p> <p>completed on: at _____ operating hours</p>
<p style="text-align: center;"><b>Hako System Maintenance I 750 operating hours Workshop Stamp</b></p> <p>completed on: at _____ operating hours</p>	<p style="text-align: center;"><b>Hako System Maintenance III 1000 operating hours Workshop Stamp</b></p> <p>completed on: at _____ operating hours</p>	<p style="text-align: center;"><b>Hako System Maintenance I 1250 operating hours Workshop Stamp</b></p> <p>completed on: at _____ operating hours</p>	<p style="text-align: center;"><b>Hako System Maintenance II 1500 operating hours Workshop Stamp</b></p> <p>completed on: at _____ operating hours</p>
<p style="text-align: center;"><b>Hako System Maintenance I 1750 operating hours Workshop Stamp</b></p> <p>completed on: at _____ operating hours</p>	<p style="text-align: center;"><b>Hako System Maintenance IV/ S 2000 operating hours Workshop Stamp</b></p> <p>completed on: at _____ operating hours</p>	<p style="text-align: center;"><b>Hako System Maintenance I 2250 operating hours Workshop Stamp</b></p> <p>completed on: at _____ operating hours</p>	<p style="text-align: center;"><b>Hako System Maintenance II 2500 operating hours Workshop Stamp</b></p> <p>completed on: at _____ operating hours</p>

## Maintenance and Service

### 5.3 Maintenance plan Hako system maintenance, customer

The following maintenance work must be completed by the customer at the intervals stipulated.

Activity	Interval
	Daily
Charge the battery	o
Check the battery acid level, fill distilled water if necessary (only towards the end of the charging process)	o
Check the rotary brush for foreign bodies, e.g. wire, tape, etc.	o
Function test of the parking brake	o
Check the tires	o
Check the hydraulic system for leaks	o
Check the service brake	o
Check the electrical system	o
Check the control and safety equipment	o
Shake the dust filter clean	o
Check the dirt hopper, empty as necessary	o
Test drive and function test	o

## Maintenance and Service

### Hako system maintenance, customer

The following maintenance work must be completed by the customer at the intervals stipulated.

Activity	Interval
	Weekly
Check the rotary brush for signs of wear, readjust or change as necessary	o
Check the function of the steering	o
Check the filter system, clean the filter as necessary	o
Check the function of the agitating device	o
Check the dirt hopper seals, replace as necessary	o
Check the side brush for signs of wear, readjust or change as necessary	o
Check the sealing strips and rotary brush for signs of wear, readjust or change as necessary	o
Clean the vehicle	o

## Maintenance and Service

### Hako system maintenance, one-off

The following maintenance work must be completed by an authorized Hako service center.

Activity	Interval
	Every 50 operating hours (one-off)
Change the hydraulic oil filter and refill the necessary oil	o
Check the rotary brush for wear and foreign bodies, e.g. wire, tape, etc.	o
Check the control lamps, acoustic warning signals, lighting system and seat contact switch of the electric system	o
Check the function of the parking brake and service brake	o
Check the function of the steering	o
Check the characteristics of the fan belt	o
Check the drive battery and charger	o
Check the traction drive (forward and reverse drive, neutral position)	o
Check the visual appearance of the vehicle	o
Test drive and function test	o

## Maintenance and Service

### Hako system maintenance I

The following maintenance work must be completed by an authorized Hako service center.

Activity	Interval
	Every 250 operating hours
Check the wheel nuts / wheel bolts are fixed properly	o
Check the hydraulic oil level; refill as necessary	o
Check the battery acid level, fill distilled water if necessary (only towards the end of the charging process)	o
Clean and grease the battery poles	o
Check the properties of the fan belt; change, if necessary	o
Check the dirt hopper seals, replace as necessary	o
Check the side brush for signs of wear, readjust or renew as necessary	o
Check the filter system and change the panel air filter	o
Check the steering	o
Check the function of the parking brake and service brake	o
Check the hydraulic functions	o
Check antistatic chain	o
Check the electric system (lighting, fuses, relays and control lamps)	o
Check the visual appearance of the vehicle	o
Test drive and function test	o



## Maintenance and Service

### Hako system maintenance II

The following maintenance work must be completed by an authorized Hako service center.

Activity	Interval
	Every 500 operating hours
All maintenance work in accordance with Hako system maintenance I	o
Change the hydraulic oil	o
Change hydraulic oil filter	o
Check the rotary brush and side brush; change, if necessary	o
Change the sealing strips	o
Clean the carbon dust from the electric motors and check the carbon brushes run easily and for signs of wear; change the carbon brushes, if necessary	o
Check the visual appearance of the vehicle	o
Test drive and function test	o

## Maintenance and Service

### Hako system maintenance III/S:

The following maintenance work must be completed by an authorized Hako service center.

Activity	Interval
	Every 1000 operating hours
All maintenance work in accordance with Hako system maintenance I and II	o
Check the retaining screws, retighten as necessary (safety check)	o
Check the carbon brushes; change as necessary	o
Check the brake system (safety check), change the brake shoes and brake Bowden cables	o
Check the steering (safety check)	o

## Maintenance and Service

### 5.4 Seat console

The drive, batteries, hydraulic system and other components are located under the seat console. The seat console can be pivoted up for cleaning and maintenance purposes.

#### 5.4.1 Opening the seat console

If the cab safety roof option is installed, the seat console is equipped with a lock.

1. Park the vehicle on a level surface.  
Switch off the vehicle with the key switch and apply the parking brake.
2. Open the side panel (Fig. 23/1) using a square wrench.
3. Unlock the lock (Fig. 23/2). Pivot the seat console up.



After pivoting the seat console back down it must be locked again and the side door closed.

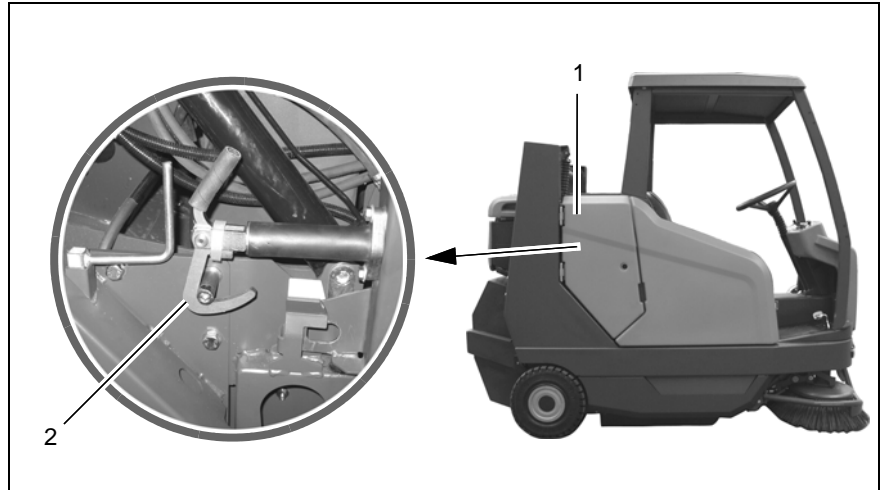

Fig.23

### 5.5 Battery system

- 1 Charge control indicator
- 2 Battery plug
- 3 Batteries
- 4 Water refilling system (option)
- 5 Connector
- 6 Brackets



The illustration depicts the PzS trough battery set 36V/450 Ah (option). In order to fix the battery cable, there are two brackets and cable ties enclosed with the battery set. Insert the brackets (Fig. 24/6) in the small battery trough (Fig. 24/3b), refer to photo.

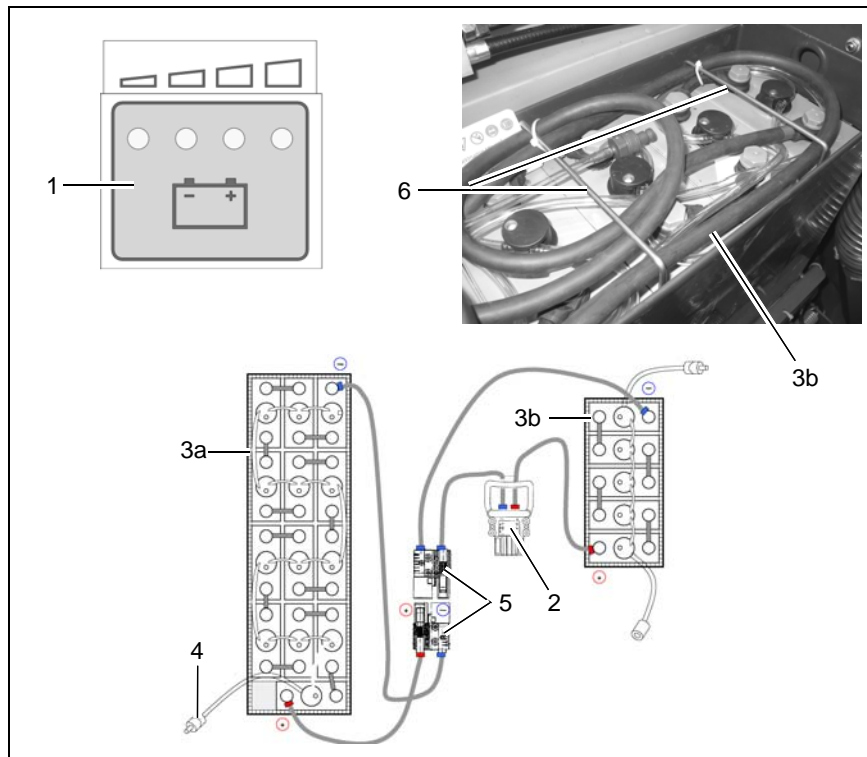

Fig.24

### Information on driving batteries

Pay attention to the information on driving batteries, refer to the Operating Manual 88-60-2556.



When working on the electric system, always switch the vehicle off and disconnect the battery plug!

Only batteries approved by Hako may be installed!

Batteries may only be handled and changed by properly skilled maintenance personnel.

After finishing work on the batteries, wash your hands thoroughly!

### 5.5.1 Total discharge signal transducer (TSG)

The vehicle is equipped with a total discharge signal transducer for protection against total discharge of the batteries. The total discharge signal transducer is set up for batteries approved by Hako.

### 5.5.2 Charging batteries

During operation, the charge control indicator (Fig. 24/1) indicates the charge status of the batteries (Fig. 24/3). When the red LED lights up, the batteries must be charged immediately.



Open the seat cover during the charging process.

1. Park the vehicle on a level area of floor.
2. Switch the vehicle off and apply the parking brake.
3. Open the side door and pivot up the seat console (refer to Section 5.4.1).
4. Disconnect the battery plug (Fig. 24/2) from the device connector and connect it to the connector on the charger.
5. Switch on the charger and monitor the charge status according to the charge control indicator.



Never leave batteries in a discharged state, always recharge them straight away!

### 5.5.3 Disassembling the batteries

1. Park the vehicle on a level area of floor.
2. Switch the vehicle off and apply the parking brake.
3. Open the side door and pivot up the seat console (refer to Section 5.4.1).
4. Disconnect the battery plug (Fig. 24/2) from the device connector. If necessary, disconnect the water refilling system (Fig. 24/4).



Only use approved lifting gear. Lifting hooks must not cause damage to cells, connectors or connection cables.  
Risk of injury!

5. Remove the batteries from the vehicle using appropriate lifting gear.

### 5.5.4 Installing the batteries

1. Park the vehicle on a level area of floor.
2. Switch the vehicle off and apply the parking brake.
3. Open the side door and pivot up the seat console (refer to Section 5.4.1).



Only use approved lifting gear. Lifting hooks must not cause damage to cells, connectors or connection cables.  
Risk of injury!

4. Install the batteries from above in the battery trough according to the figure.
5. Connect the battery poles to the connection cables in accordance with the connection diagram (see figure 5).



Sparking may occur when connecting the batteries. Ensure they are connected firmly.  
Risk of injury!

6. Connect the battery plug (Fig. 24/2) to the device connector. If necessary, connect the water refilling system (Fig. 24/4).
7. Pivot the seat console back down

(refer to Section 5.4.1) and close the side door.

### 5.5.5 Disposing of batteries

Used batteries with the recycling symbol contain reusable commodities. In accordance with symbol with the crossed out garbage bin, these batteries must not be disposed of in domestic waste. Return and recycling must be agreed on with Hako's authorized dealer in accordance with § 6 and 8 BattV (Battery Directive)!

### 5.6 Hydraulic system



Work on the hydraulic system may only be carried out by technical experts and correspondingly trained personnel! Hydraulic oil under high pressure can cause severe injuries!

- 1 Hydraulic oil filter
- 2 Cap
- 3 Hydraulic oil tank

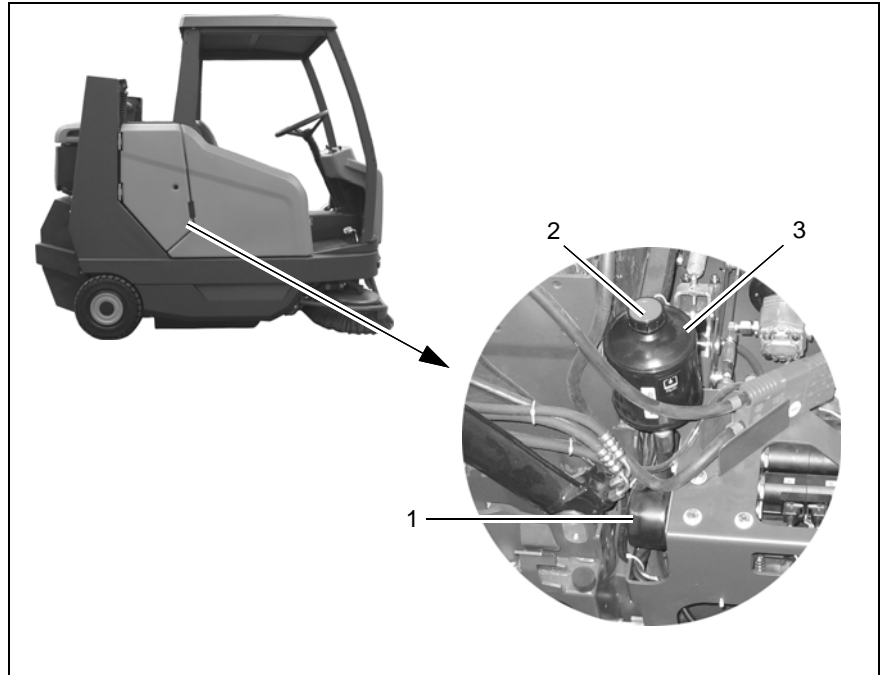

Fig.25

## Maintenance and Service

### 5.6.1 Filling hydraulic oil

Check the oil level of the hydraulic oil tank every day.



Only use the hydraulic oil prescribed, refer to Technical Data! Shortages of hydraulic oil or incorrect hydraulic oil leads to damage to the hydraulic system!

The dirt hopper must be in its bottom position!

1. Open the seat console, refer to Section 5.4.
2. Remove the cap (Fig. 25/2).
3. Check the oil level on the fill level indicator in the cap (Fig. 25/2) of the hydraulic oil tank (Fig. 25/3).
4. Do not pour in too much oil at one time. Measure the oil level again.
5. Replace the cap.

### 5.6.2 Changing the hydraulic oil

The hydraulic oil must be changed every 500 operating hours.



Take the utmost care when draining hot hydraulic oil. Risk of burns!

1. Park the vehicle on an even surface and lower the dirt hopper. Switch the engine off and apply the parking brake.
2. Use a suitable collecting vessel. Oil quantity: approx. 1.5 l.
3. Disconnect the hydraulic hose from the hydraulic pump. Allow the hydraulic oil to drain off into the collecting vessel.



Dispose of the used hydraulic oil according to the applicable environmental regulations!

4. Fix the hydraulic hose to the hydraulic pump and refill hydraulic oil refer to Section 5.6.1.
5. Start the vehicle and, when running at a slow speed, put all the work functions into operation and raise and empty the dirt hopper several times. Switch the vehicle off again.
6. Refill more hydraulic oil, if necessary. Check the hydraulic system for leaks.

### 5.6.3 Change hydraulic oil filter

The hydraulic oil filter must be changed for the first time after 50 operating hours

and subsequently every 500 operating hours.



Take the utmost care when draining hot hydraulic oil. Risk of burns!

1. Park the vehicle on an even surface and lower the dirt hopper. Switch the engine off and apply the parking brake.
2. Unscrew the hydraulic oil filter (Fig. 25/1).



Dispose of the used hydraulic oil filter according to environmental regulations!

3. Install new hydraulic oil filter with new sealing rings (tighten hand-tight). Only use original spare parts!
4. Start the vehicle and switch it off again. Check the hydraulic system for leaks.



### 5.7 Sweeping unit

- 1 Side brushes
- 2 Rotary brush
- 3 Sweepings container
- 4 Suction turbine
- 5 Filter system

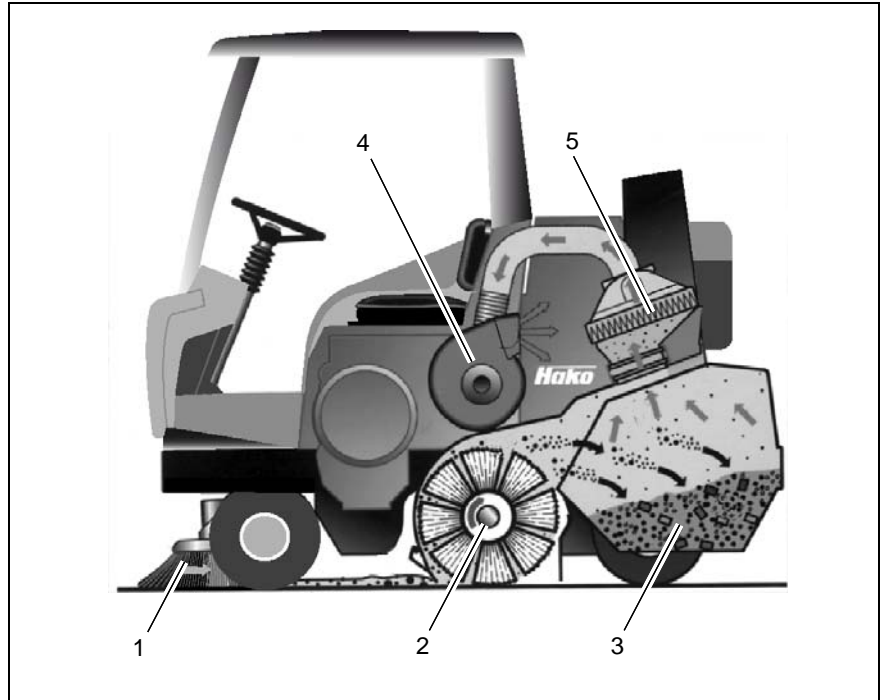

Fig.26

### 5.7.1 Side brushes

- 1 Adjusting bolt
- 2 Side brushes
- 3 Catch

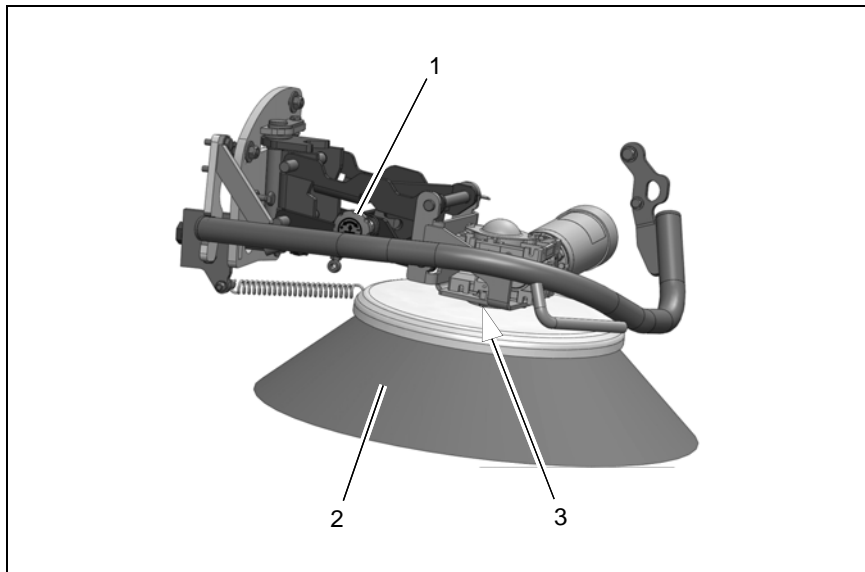

Fig.27

### 5.7.2 Adjusting the side brushes

Check the side brushes (Fig. 27/2) every week for signs of wear. In the event of wear or after the side brushes have been changed, proceed as follows to complete the necessary adjustments:

1. Park the vehicle on a level surface.  
Switch the engine off and apply the parking brake.
2. Adjust the contact surface of the side brush (Fig. 27/2) using the adjusting bolt (Fig. 27/1). The contact surface of the side brush should be approx.  $\frac{2}{3}$  of the brush circumference.

### 5.7.3 Changing the side brushes

When the brushes have worn to a bristle length of 8 cm or less, the side brushes must be replaced.

1. Park the vehicle on a level surface.  
Switch the engine off and apply the parking brake.
2. Loosen the screws and washers on the catch (Fig. 27/3) and remove the side brush (Fig. 27/2).
3. Install the new side brush. Only use original spare parts!
4. Adjust the side brush, refer to Section 5.7.2.

## Maintenance and Service

### 5.7.4 Rotary brush

- 1 Rotary brush
- 2 Sealing strip, left
- 3 Sealing strip, front
- 4 Sealing strip, rear
- 5 Sealing strip, right
- 6 Rotary brush half
- 7 Screw connection (5 pieces)
- 8 Crank for rotary brush adjustment
- 9 Scale

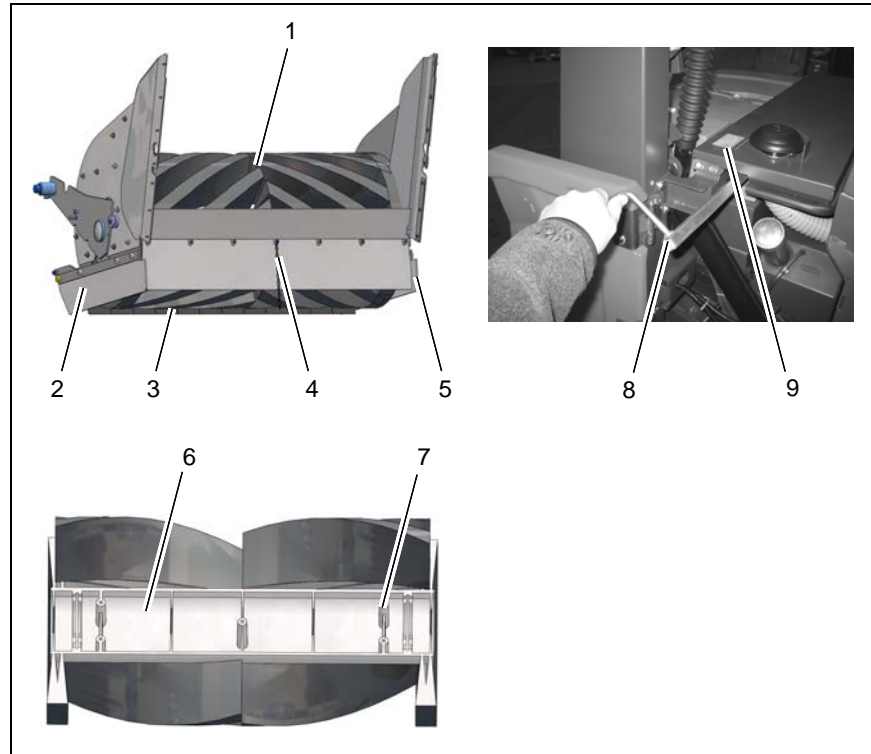

Fig.28

### 5.7.5 Setting the sweeping pattern

Check the rotary brush (Fig. 28/1) every week for signs of wear. In the event of wear or after the rotary brush has been changed, proceed as follows to complete the necessary adjustments:

1. Lower the rotary brush onto a smooth floor and allow to rotate for a short time while the vehicle has stopped.
2. Raise the rotary brush and drive the vehicle forwards a little.
3. Raise the sweepings container.
4. Switch the machine off and apply the parking brake.
5. Check the degree of wear. When setup correctly, the rotary brush must produce a parallel sweeping track, 75 +/- 10 mm wide, on the floor.
6. Fit the crank (Fig. 28/8) on the square and adjust the sweeping pattern.
  - Turn clockwise: smaller sweeping pattern
  - Counterclockwise: larger sweeping patternThe value is indicated on the scale (Fig. 28/9).

### 5.7.6 Aligning the rotary brush parallel

The rotary brush is set parallel at the factory. If the parallel alignment is no longer set, please contact an authorized Hako service center.

### 5.7.7 Changing the rotary brush

In the case of wear resulting in a bristle length of at least 100 mm, the rotary brush must be changed. The rotary brush can be accessed from the rear when the sweepings container has been raised and can be disassembled as follows:

1. Park the vehicle on a level area of floor.
2. Raise the sweepings container.
3. Switch the machine off and apply the parking brake.
4. Turn back the crank (Fig. 28/8) to zero.
5. Turn the rotary brush by hand until the five screw connections (Fig. 28/7) are visible.
6. Loosen the screw connections and remove the rotary brush half (Fig. 28/6).
7. Turn the second rotary brush half further and pull out to the rear (the

rotary brush is held by clamps).

8. Install the new rotary brush in the reverse sequence. Only use original spare parts!
9. When assembling the rotary brush, pay attention that the clamps engage in the catches and to the direction of the bristles. The alignment of the bristles must conform to that illustrated in the figure.
10. Adjust the sweeping pattern, refer to Section 5.7.5.

## Maintenance and Service

### 5.7.8 Adjusting the sealing strips

Check the sealing strips in the rotary brush area every week, readjust as necessary.

1. Park the vehicle on a level area of floor.
2. Raise the sweepings container.
3. Switch the machine off and apply the parking brake.
4. The side sealing strips (Fig. 28/2) and (Fig. 28/5) can be adjusted via the slots. The sealing strip must have a clearance of approx. 1 mm to the floor.
5. The front sealing strip (Fig. 28/3) can be adjusted using an actuating rod. The sealing strip must make contact with the floor and bend slightly to the rear.
6. The rear sealing strip (Fig. 28/4) can be adjusted via the slots. The sealing strip must have a clearance of approx. 5 mm to the floor.

### 5.7.9 Changing the sealing strips

Check the sealing strips in the rotary brush area weekly for signs of wear, re-adjust as necessary. Replace worn sealing strips.

1. Park the vehicle on a level area of floor.
2. Raise the sweepings container.
3. Switch the machine off and apply the parking brake.
4. Loosen and remove the sealing strips and replace by new ones. Only use original spare parts!
5. Adjust the sealing strips, refer to Section 5.7.8.

## Maintenance and Service

### 5.7.10 Filter system

- 1 Lock
- 2 Cover
- 3 Holder
- 4 Wing bolt
- 5 Frame
- 6 Agitating device
- 7 Dust filter

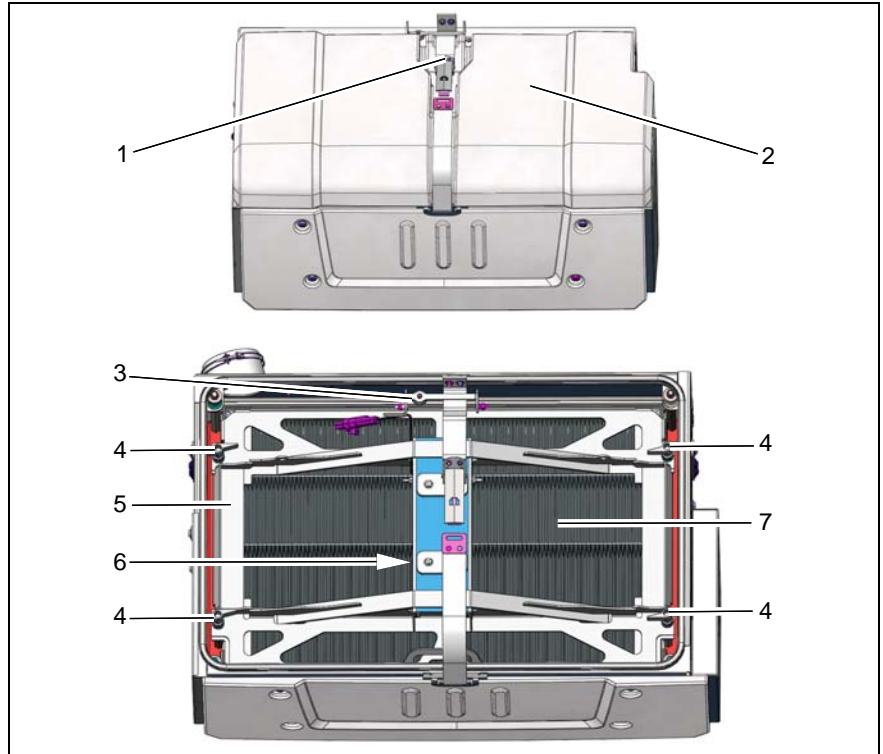

Fig.29

### 5.7.11 Cleaning the dust filter

The dust filter (Fig. 29/7) is located under the cover (Fig. 29/2). The fine dust swirled up by the rotary brush is drawn into the filter element by the suction turbine. Check the level of dirt in the dust filter weekly.



Clean the dust filter outdoors and wear a dust mask when doing so! Dispose of the dust according to the applicable environmental laws!

1. Park the vehicle on a level area of floor. Switch the machine off and apply the parking brake.
2. Open the lock (Fig. 29/1) on the cover (Fig. 29/2).
3. Loosen the wing bolts (Fig. 29/4), pivot up the frame (Fig. 29/5) with the agitating device (Fig. 29/6) and allow it to engage in the holder (Fig. 29/3).
4. Remove the dust filter (Fig. 29/7).
5. Drop the dust filter horizontally onto level ground from a height of approx. 1 meter (soiled side must face the ground!).
6. Install the dust filter again in the reverse sequence.

### 5.7.12 Changing the dust filter

1. Park the vehicle on a level area of floor. Switch the machine off and apply the parking brake.
2. Open the lock (Fig. 29/1) on the cover (Fig. 29/2).
3. Loosen the wing bolts (Fig. 29/4), pivot up the frame (Fig. 29/5) with the agitating device (Fig. 29/6) and allow it to engage in the holder (Fig. 29/3).
4. Remove the dust filter (Fig. 29/7).
5. Install the new dust filter in the reverse sequence. Only use original spare parts! Pay attention to the direction of installation, refer to imprint.
6. Check the function of the agitating device.



### 5.8 Wheels and brakes

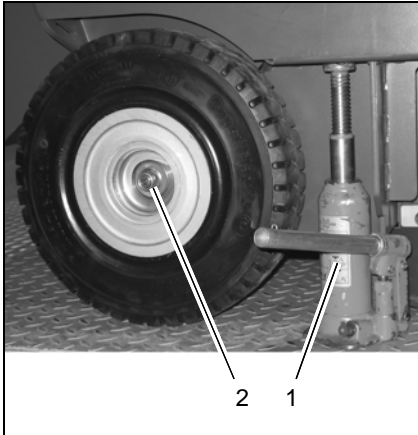

Fig.30

#### 5.8.1 Checking tire wear

Check the tires weekly for signs of wear and tread depth.

#### 5.8.2 Changing tires



Work on the wheels may only be carried out by technical experts and correspondingly trained personnel!

1. Park the vehicle on a level surface and secure against rolling away.
2. Switch the engine off and remove the ignition key.
3. Bring the jack (Fig. 30/1) into position under the frame.
4. Raise the vehicle with the jack.
5. Remove the nut and the washer.
6. Remove the tires with rims.
7. Mount new tires. Only use original spare parts!
8. Tighten the nut at a torque of 50 Nm.

#### 5.8.3 Brakes



Work on the brake system may only be carried out by technical experts and correspondingly trained personnel!

The service brake and parking brake must be checked after the first 50 operating hours and subsequently after every 250 operating hours in use. The brake shoes must be changed every 1000 operating hours.

## Maintenance and Service

### 5.9 Electronics

#### 5.9.1 Fuses

The fuse box (Fig. 31/1) is on the right-hands of the foot area. The main fuse and pre-fuse are located in the engine compartment in front of the battery.

- F1 Main fuse (200A)
- F2 Pre-fuse (50A)
- F3 Indicator (10A) (option)
- F4 Spare
- F5 RKL 12V (7,5A) (option)
- F6 Parking/Rear light, right (5A) (option)
- F7 Parking/Rear light, left (5A) (option)
- F8 Driving lights (15A)
- F9 DC/DC converter (20A)
- F10 Modules (10A)
- F11 RKL 36V (7.5A) (option)
- F12 Horn (7.5A)
- F13 Working lights (10A) (option)
- F14 Windscreen wipers (10A) (option)
- F15 Control relay 24V (5A)
- F19 Hydraulic motor (100A)

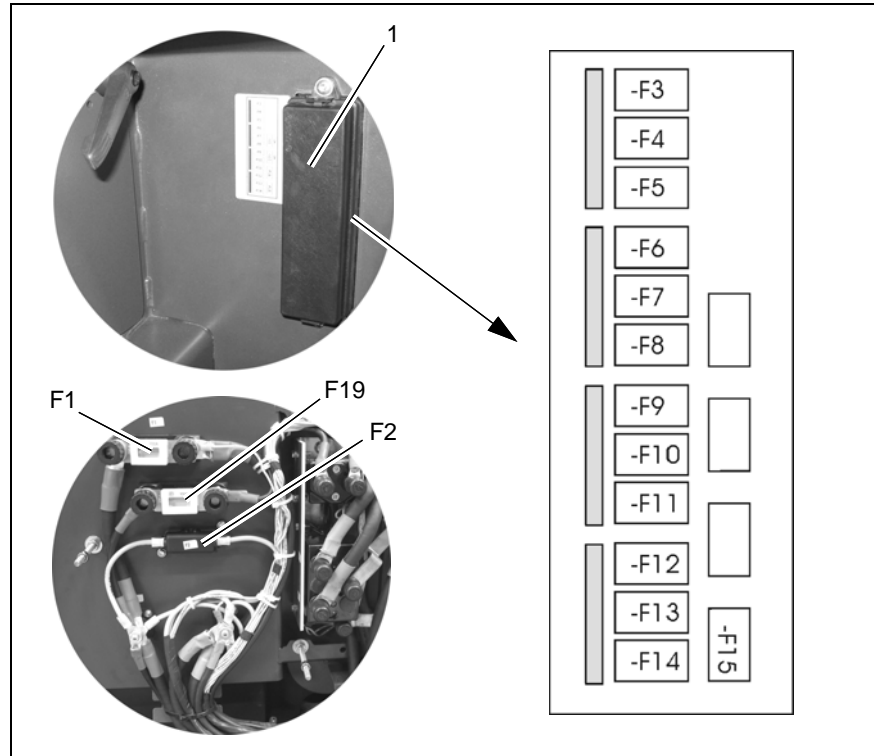

Fig.31

## Maintenance and Service

### 5.9.2 Relays

K2 Relay, hydraulic motor

K3 Changeover relay, driving direction forwards/reverse

K4 Relay, Driving lights 24V or Relay, working lights 24V (option)

K6 Relay 24V, windscreen wipers

K8 Indicator relay, (option)

A = Drive control

B = Steering column, front view

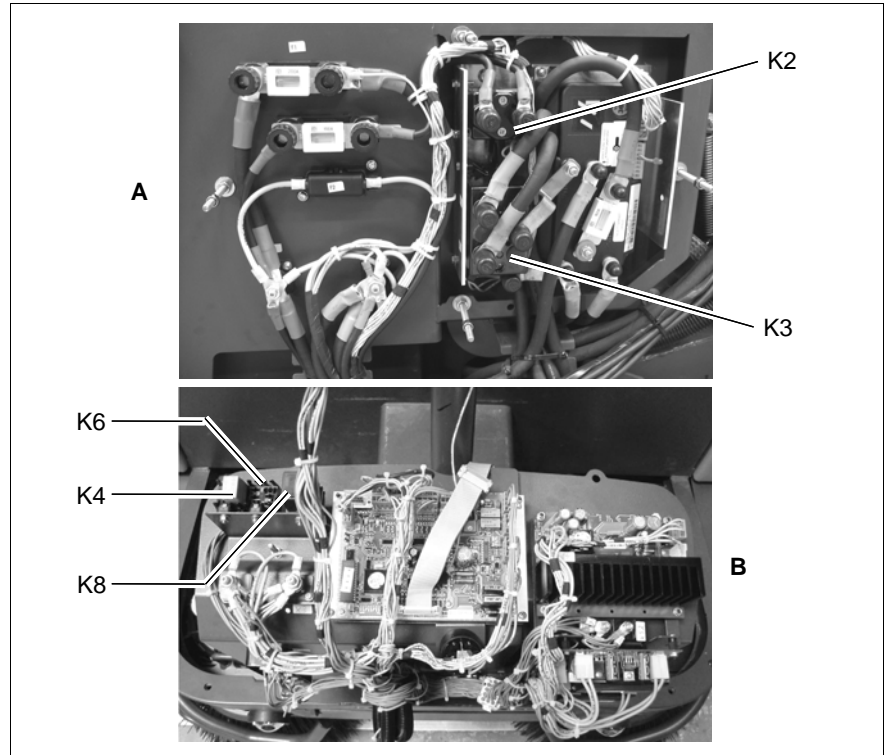

Fig.32

## Maintenance and Service

### 5.10 Special equipment and replacement demands

Name	Description	Order no.
Cab safety roof	Based on IEC 60335-2-72 CC	6474
Side brush, left	Supplied with standard brushes	646840
Flashing beacon	On pole, for installation without cab safety roof (36 Volt)	643336
Flashing beacon	For installation on cab safety roof (36 Volt)	644236
Working lights	2 pieces, integrated at the front of the vehicle frame	643436
Lighting system	To acquire a vehicle type approval (in accordance with StVZO (road traffic licensing regulation))	643136
Flashing beacon	On pole, for installation without cab safety roof (12 Volt)	643302
Flashing beacon	For installation on cab safety roof (12 Volt)	643312
Spare rotary brush	With PP bristles, hard bristles (standard)	6457
Spare rotary brush	With PES bristles, soft bristles	6413
Spare rotary brush	With PA bristles, medium bristles (wear-resistant)	6455
Spare side brush	PA bristles (PA 1.5), medium bristles	6414
Spare side brush	PA bristles (PA 2,0) (standard)	6423
Spare side brush	With PES bristles, soft bristles	6415

## EC Declaration of Conformity (corresponds to EC Directive 2006/42/EC)

**Hako GmbH**  
**Hamburger Straße 209-239**  
**D-23843 Bad Oldesloe**

declares that the product

**Sweepmaster B1500 RH**  
**Typ: 6464.40**

to which this declaration relates, conform to the relevant provisions of the safety and health requirements stipulated in EC Directive 2006/42/EC and is in accordance with 2004/108/EC.

Reference was made to the following standards and/or norms and/or technical specifications to ensure proper implementation of the safety and health requirements in the EC Directive:

**DIN EN 60335-2-72**  
**DIN EN 61000-6-2**  
**DIN EN 55012**

Bad Oldesloe, 22.04.2014



Dr. Rainer Bavendiek  
Director R&D

Name of the authorized person who compiles technical documents for Hako:

Ludger Lüttel

# **Hako**

*Clean ahead*

# Spitzentechnik für eine saubere und schönere Umwelt

Advanced Technology for a Cleaner, Better Environment



Hako GmbH • Hamburger Str. 209-239 • D-23843 Bad Oldesloe  
☎ +49 4531 806-0 • Fax +49 4531 806-338

88-10-2943 - 3100-11